



# Hardware Maintenance Manual

Lenovo E50-80

**Note:** Before using this information and the product it supports, be sure to read the general information under Appendix A “Notices” on page 81.

**First Edition (January 2015)**

**© Copyright Lenovo 2015.**

LIMITED AND RESTRICTED RIGHTS NOTICE: If data or software is delivered pursuant a General Services Administration “GSA” contract, use, reproduction, or disclosure is subject to restrictions set forth in Contract No. GS-35F-05925.

---

# Contents

<b>About this manual.</b> . . . . .	<b>iii</b>	<b>Chapter 8. Locations</b> . . . . .	<b>33</b>
<b>Chapter 1. Safety information.</b> . . . .	<b>1</b>	Locating FRUs and CRUs . . . . .	33
General safety . . . . .	1	Major FRUs and CRUs. . . . .	34
Electrical safety . . . . .	1	LCD FRUs . . . . .	40
Safety inspection guide . . . . .	2	Miscellaneous parts and other FRUs . . . . .	41
Handling devices that are sensitive to electrostatic discharge. . . . .	3	<b>Chapter 9. FRU replacement notices</b> . . . . .	<b>49</b>
Grounding requirements . . . . .	4	Screw notices . . . . .	49
Safety notices (multilingual translations). . . . .	4	<b>Chapter 10. Removing or replacing a FRU</b> . . . . .	<b>51</b>
<b>Chapter 2. Important service information</b> . . . . .	<b>19</b>	General guidelines . . . . .	51
Strategy for replacing FRUs . . . . .	19	1010 External battery pack . . . . .	52
Strategy for replacing a hard disk drive or a solid-state drive . . . . .	19	1020 Keyboard . . . . .	52
Important notice for replacing a system board . . . . .	20	1030 Optical disk drive . . . . .	54
FRU identification. . . . .	20	1040 Base cover assembly . . . . .	56
<b>Chapter 3. General checkout</b> . . . . .	<b>21</b>	1050 Hard disk drive or solid-state hybrid drive . . . . .	58
What to do first . . . . .	21	1060 Wireless-LAN /Bluetooth card . . . . .	59
Power system checkout . . . . .	22	1070 Memory module . . . . .	60
Checking the ac power adapter . . . . .	22	1080 Upper case. . . . .	61
Checking the external battery pack and the operational charging . . . . .	23	1090 Audio board, audio board cable, power board, touch pad board cable, finger printer board, LED board and ODD switch board . . . . .	63
<b>Chapter 4. Related service information</b> . . . . .	<b>25</b>	1100 System board . . . . .	66
Restoring the factory contents by using OneKey Recovery . . . . .	25	1110 Battery Board, Thermal fan assembly and Heat Sink assembly. . . . .	69
Power management . . . . .	25	1120 Speaker assembly, docking LED lens and docking bracket . . . . .	72
Screen blank mode (for the Windows 7 operating system only). . . . .	25	1130 LCD unit, docking board, docking cable and DC-in cable . . . . .	73
Sleep mode . . . . .	25	1140 LCD front bezel . . . . .	76
Hibernation mode . . . . .	26	1150 LCD panel, EDP cable and hinges . . . . .	76
<b>Chapter 5. Passwords</b> . . . . .	<b>27</b>	1160 Integrated camera and LCD cable . . . . .	78
Power-on password . . . . .	27	1170 Antenna assembly and LCD cover. . . . .	79
Hard disk password . . . . .	27	<b>Appendix A. Notices.</b> . . . . .	<b>81</b>
Administrator password . . . . .	27	Electronic emissions notices . . . . .	82
<b>Chapter 6. Status indicators</b> . . . . .	<b>29</b>	Trademarks . . . . .	82
<b>Chapter 7. Function keys</b> . . . . .	<b>31</b>	<b>Appendix B. Abbreviation table</b> . . . . .	<b>83</b>





---

## About this manual

This manual contains service and reference information for the following Lenovo® products.

Lenovo E50–80

Machine Type (MT) 80JA and 80J2

Use this manual along with the advanced diagnostic tests to troubleshoot problems.

**Important:** This manual is intended only for trained service technicians who are familiar with Lenovo products. Use this manual along with the advanced diagnostic tests to troubleshoot problems effectively. Before servicing a Lenovo product, be sure to read all the information under Chapter 1 “Safety information” on page 1 and Chapter 2 “Important service information” on page 19.



---

## Chapter 1. Safety information

This chapter presents following safety information that you need to be familiar with before you service a Lenovo notebook computer.

- “General safety” on page 1
- “Electrical safety” on page 1
- “Safety inspection guide” on page 2
- “Handling devices that are sensitive to electrostatic discharge” on page 3
- “Grounding requirements” on page 4
- “Safety notices (multilingual translations)” on page 4

---

### General safety

Follow these rules to ensure general safety:

- Observe good housekeeping in the area of the machines during and after maintenance.
- When lifting any heavy object:
  1. Make sure that you can stand safely without slipping.
  2. Distribute the weight of the object equally between your feet.
  3. Use a slow lifting force. Never move suddenly or twist when you attempt to lift.
  4. Lift by standing or by pushing up with your leg muscles; this action removes the strain from the muscles in your back. *Do not attempt to lift any object that weighs more than 16 kg (35 lb) or that you think is too heavy for you.*
- Do not perform any action that causes hazards to the customer, or that makes the equipment unsafe.
- Before you start the machine, make sure that other service technicians and the customer's personnel are not in a hazardous position.
- Place removed covers and other parts in a safe place, away from all personnel, while you are servicing the machine.
- Keep your tool case away from walk areas so that other people will not trip over it.
- Do not wear loose clothing that can be trapped in the moving parts of a machine. Make sure that your sleeves are fastened or rolled up above your elbows. If your hair is long, fasten it.
- Insert the ends of your necktie or scarf inside clothing or fasten it with a non-conductive clip, about 8 centimeters (3 inches) from the end.
- Do not wear jewelry, chains, metal-frame eyeglasses, or metal fasteners for your clothing.

**Attention:** Metal objects are good electrical conductors.

- Wear safety glasses when you are hammering, drilling, soldering, cutting wire, attaching springs, using solvents, or working in any other conditions that might be hazardous to your eyes.
- After service, reinstall all safety shields, guards, labels, and ground wires. Replace any safety device that is worn or defective.
- Reinstall all covers correctly before returning the machine to the customer.
- Fan louvers on the machine help to prevent overheating of internal components. Do not obstruct fan louvers or cover them with labels or stickers.

---

### Electrical safety

Observe the following rules when working on electrical equipment.

**Important:** Use only approved tools and test equipment. Some hand tools have handles covered with a soft material that does not insulate you when working with live electrical currents. Many customers have, near their equipment, rubber floor mats that contain small conductive fibers to decrease electrostatic discharges. Do not use this type of mat to protect yourself from electrical shock.

- Find the room emergency power-off (EPO) switch, disconnecting switch, or electrical outlet. If an electrical accident occurs, you can then operate the switch or unplug the power cord quickly.
- Do not work alone under hazardous conditions or near equipment that has hazardous voltages.
- Disconnect all power before:
  - Performing a mechanical inspection
  - Working near power supplies
  - Removing or installing main units
- Before you start to work on the machine, unplug the power cord. If you cannot unplug it, ask the customer to power-off the wall box that supplies power to the machine, and to lock the wall box in the off position.
- If you need to work on a machine that has *exposed* electrical circuits, observe the following precautions:
  - Ensure that another person, familiar with the power-off controls, is near you.

**Attention:** Another person must be there to switch off the power, if necessary.

- Use only one hand when working with powered-on electrical equipment; keep the other hand in your pocket or behind your back.

**Attention:** An electrical shock can occur only when there is a complete circuit. By observing the above rule, you may prevent a current from passing through your body.

- When using testers, set the controls correctly and use the approved probe leads and accessories for that tester.
- Stand on suitable rubber mats (obtained locally, if necessary) to insulate you from grounds such as metal floor strips and machine frames.

Observe the special safety precautions when you work with very high voltages; Instructions for these precautions are in the safety sections of maintenance information. Use extreme care when measuring high voltages.

- Regularly inspect and maintain your electrical hand tools for safe operational condition.
- Do not use worn or broken tools and testers.
- *Never assume* that power has been disconnected from a circuit. First, *check* that it has been powered off.
- Always look carefully for possible hazards in your work area. Examples of these hazards are moist floors, non-grounded power extension cables, power surges, and missing safety grounds.
- Do not touch live electrical circuits with the reflective surface of a plastic dental mirror. The surface is conductive; such touching can cause personal injury and machine damage.
- Do not service the following parts *with the power on* when they are removed from their normal operating places in a machine:
  - Power supply units
  - Pumps
  - Blowers and fans
  - Motor generators
  - Similar units as listed above
 This practice ensures correct grounding of the units.
- If an electrical accident occurs:
  - Use caution; do not become a victim yourself.
  - Switch off power.
  - Send another person to get medical aid.

---

## Safety inspection guide

The purpose of this inspection guide is to assist you in identifying potentially unsafe conditions. As each machine was designed and built, required safety items were installed to protect users and service technicians from injury. This guide addresses only those items. You should use good judgment to identify potential safety hazards due to attachment of non-Lenovo features or options not covered by this inspection guide.

If any unsafe conditions are present, you must determine how serious the apparent hazard could be and whether you can continue without first correcting the problem.

Consider these conditions and the safety hazards they present:

- Electrical hazards, especially primary power (primary voltage on the frame can cause serious or fatal electrical shock)
- Explosive hazards, such as a damaged cathode ray tube (CRT) face or a bulging capacitor
- Mechanical hazards, such as loose or missing hardware

To determine whether there are any potentially unsafe conditions, use the following checklist at the beginning of every service task. Begin the checks with the power off, and the power cord disconnected.

Checklist:

1. Check exterior covers for damage (loose, broken, or sharp edges).
2. Power off the computer. Disconnect the power cord.
3. Check the power cord for:
  - a. A third-wire ground connector in good condition. Use a meter to measure third-wire ground continuity for 0.1 ohm or less between the external ground pin and the frame ground.
  - b. The power cord should be the authorized type specified for your computer.
  - c. Insulation must not be frayed or worn.
4. Check for cracked or bulging batteries.
5. Remove the cover.
6. Check for any obvious non-Lenovo alterations. Use good judgment as to the safety of any non-Lenovo alterations.
7. Check inside the unit for any obvious unsafe conditions, such as metal filings, contamination, water or other liquids, or signs of fire or smoke damage.
8. Check for worn, frayed, or pinched cables.
9. Check that the power-supply cover fasteners (screws or rivets) have not been removed or tampered with.

---

## Handling devices that are sensitive to electrostatic discharge

Any computer part containing transistors or integrated circuits (ICs) should be considered sensitive to electrostatic discharge (ESD). ESD damage can occur when there is a difference in charge between objects. Protect against ESD damage by equalizing the charge so that the machine, the part, the work mat, and the person handling the part are all at the same charge.

### Notes:

1. Use product-specific ESD procedures when they exceed the requirements noted here.
2. Make sure that the ESD protective devices you use have been certified (ISO 9000) as fully effective.

When handling ESD-sensitive parts:

- Keep the parts in protective packages until they are inserted into the product.
- Avoid contact with other people.
- Wear a grounded wrist strap against your skin to eliminate static on your body.
- Prevent the part from touching your clothing. Most clothing is insulative and retains a charge even when you are wearing a wrist strap.
- Use a grounded work mat to provide a static-free work surface. The mat is especially useful when handling ESD-sensitive devices.
- Select a grounding system, such as those listed below, to provide protection that meets the specific service requirement.

**Note:** The use of a grounding system to guard against ESD damage is desirable but not necessary.

- Attach the ESD ground clip to any frame ground, ground braid, or green-wire ground.
- When working on a double-insulated or battery-operated system, use an ESD common ground or reference point. You can use coax or connector-outside shells on these systems.

- Use the round ground prong of the ac plug on ac-operated computers.

---

## Grounding requirements

Electrical grounding of the computer is required for operator safety and correct system function. Proper grounding of the electrical outlet can be verified by a certified electrician.

---

## Safety notices (multilingual translations)

The safety notices in this section are provided in the following languages:

- English
- Arabic
- Brazilian Portuguese
- French
- German
- Hebrew
- Japanese
- Korean
- Spanish
- Traditional Chinese



### DANGER

Before the computer is powered on after FRU replacement, make sure that all screws, springs, and other small parts are in place and are not left loose inside the computer. Verify this by shaking the computer and listening for rattling sounds. Metallic parts or metal flakes can cause electrical short circuits.



### DANGER

Some standby batteries contain a small amount of nickel and cadmium. Do not disassemble a standby battery, recharge it, throw it into fire or water, or short-circuit it. Dispose of the battery as required by local ordinances or regulations. Use only the battery in the appropriate parts listing. Use of an incorrect battery can result in ignition or explosion of the battery.



### DANGER

The battery pack contains small amounts of nickel. Do not disassemble it, throw it into fire or water, or short-circuit it. Dispose of the battery pack as required by local ordinances or regulations. Use only the battery in the appropriate parts listing when replacing the battery pack. Use of an incorrect battery can result in ignition or explosion of the battery.



## DANGER

The lithium battery can cause a fire, an explosion, or a severe burn. Do not recharge it, remove its polarized connector, disassemble it, heat it above 100°C (212°F), incinerate it, or expose its cell contents to water. Dispose of the battery as required by local ordinances or regulations. Use only the battery in the appropriate parts listing. Use of an incorrect battery can result in ignition or explosion of the battery.



## DANGER

If the LCD breaks and the fluid from inside the LCD gets into your eyes or on your hands, immediately wash the affected areas with water for at least 15 minutes. Seek medical care if any symptoms from the fluid are present after washing.



## DANGER

To avoid shock, do not remove the plastic cover that protects the lower part of the inverter card.



## DANGER

Though the main batteries have low voltage, a short-circuited or grounded battery can produce enough current to burn personnel or combustible materials.



## DANGER

Unless hot swap is allowed for the FRU being replaced, do as follows before removing it: power off the computer, unplug all power cords from electrical outlets, remove the battery pack, and disconnect any interconnecting cables.



قبل إعادة تشغيل الحاسب بعد الانتهاء من استبدال FRU، تأكد من أنه قد تم إعادة كل من المسامير و السويت وكل الأجزاء الصغيرة الأخرى في أماكنهم ولم يتم فقدهم داخل الحاسب. ويمكن التحقق من ذلك عن طريق هز الحاسب والاستماع لأي صوت صاخب يصدر منه. قد تؤدي الأجزاء أو الرقائق المعدنية إلى حدوث دائرة قصر.



خطر

تحتوي بعض البطاريات الاحتياطية على كمية صغيرة من مادتي النيكل والكاديوم. لا تقم بفك أو إعادة شحن البطارية الاحتياطية ولا تقم أيضا بالقائها في النار أو الماء ولا تتسبب في احدث دائرة قصر بها. قم بالتخلص من البطارية كما هو موضح في القوانين المحلية. استخدم نوع البطارية المحدد والذي يوصى باستخدامه. حيث أنه قد يؤدي استخدام نوع بطارية غير صحيح الى اشتعالها أو انفجارها.



خطر

تحتوي حزمة البطارية على كمية صغيرة من مادة النيكل. لا تقم بفكها أو القاءها في النار أو الماء ولا تتسبب في احدث دائرة قصر بها. تخلص من حزمة البطارية وفقا لما هو موضح في القوانين المحلية. قم، عند استبدال حزمة البطارية، باستخدام الأنواع المحددة فقط والتي يوصى باستخدامها. حيث أنه قد يؤدي استخدام نوع بطارية غير صحيح الى اشتعالها أو انفجارها.



خطر

قد تتسبب بطارية الليثيوم في حدوث حريق أو انفجار أو حدوث حروق شديدة. لا تقم بإعادة شحن البطارية أو إزالة موصل الاستقطاب الخاص بها ولا تحاول أيضا فكها أو تسخينها لأكثر من ١٠٠ درجة مئوية (٢١٢١ فهرنهايت) أو حرقها أو تعريض محتويات الخانة الخاصة بها للماء. قم بالتخلص من البطارية وفقا لما هو موضح في القوانين المحلية. استخدم نوع البطارية المحدد والذي يوصى باستخدامه. حيث أنه قد يؤدي استخدام نوع بطارية غير صحيح الى اشتعالها أو انفجارها.



خطر

إذا ما انكسرت شاشة LCD ولامس السائل الداخلي عينيك أو يديك، قم في الحال بغسلهما بالماء لمدة لا تقل عن ١٥ دقيقة. إذا ما وجدت أي أعراض بعد الغسل اطلب عندئذ المساعدة الطبية.



خطر

لتجنب التعرض لأي صدمات، لا تقم بإزالة الغطاء البلاستيكي الذي يحمي الجزء الأسفل من بطاقة العاكس.



خطر



على الرغم من أن البطاريات الرئيسية يكون لها جهد منخفض، إلا أنه قد تقوم البطاريات التي حدث قصور بها أو التي تم توصيلها أرضيا بإصدار تيار يكفي لحدوث حروق للأفراد أو تعرض المواد القابلة للاشتعال للحريق.



خطر

ما لم يتم السماح بالتبديل الفوري لأي FRU الجاري استبداله بدون ضرورة اغلاق النظام، قم بتنفيذ ما يلي قبل ازالته. قم بإيقاف تشغيل الحاسب ونزع كل أسلاك الطاقة من المخارج الكهربائية وقم أيضا بإزالة حزمة البطارية ثم قم بفصل أي كابلات متصلة.



#### PERIGO

Antes de ligar o computador após a substituição da FRU, certifique-se de que todos os parafusos, molas e outras peças pequenas estejam no lugar e não estejam soltos dentro do computador. Verifique isso sacudindo o computador e procurando ouvir sons de peças soltas. Peças metálicas ou lascas de metal podem causar curto-circuito.



#### PERIGO

Algumas baterias reserva contêm uma pequena quantidade de níquel e cádmio. Não desmonte uma bateria reserva, recarregue-a, jogue-a no fogo ou na água, ou deixe-a entrar em curto-circuito. Descarte a bateria conforme requerido pelas leis ou regulamentos locais. Use somente a bateria nas partes listadas apropriadas. O uso de uma bateria incorreta pode resultar em combustão ou explosão da bateria.



#### PERIGO

O pacote da bateria contém uma pequena quantidade de níquel. Não o desmonte, jogue-o no fogo ou na água, ou deixe-o entrar em curto-circuito. Descarte o pacote da bateria conforme requerido pelas leis ou regulamentos locais. Use somente a bateria nas partes listadas apropriadas ao substituir o pacote da bateria. O uso de uma bateria incorreta pode resultar em combustão ou explosão da bateria.



#### PERIGO

A bateria de lítio pode causar incêndio, explosão ou graves queimaduras. Não a recarregue, remova seu conector polarizado, desmonte-a, aqueça-a acima de 100°C (212°F), incinere-a, ou exponha o conteúdo de sua célula à água. Descarte a bateria conforme requerido pelas leis ou regulamentos locais. Use somente a bateria nas partes listadas apropriadas. O uso de uma bateria incorreta pode resultar em combustão ou explosão da bateria.



## PERIGO

Se o LCD quebrar e o fluido de dentro dele entrar em contato com seus olhos ou com suas mãos, lave as áreas afetadas imediatamente com água durante pelo menos 15 minutos. Procure cuidados médicos se algum sintoma causado pelo fluido surgir após a lavagem.



## PERIGO

Para evitar choque elétrico, não remova a capa plástica que protege a parte inferior da placa inversora.



## PERIGO

Embora as principais baterias possuam baixa voltagem, uma bateria em curto-circuito ou aterrada pode produzir corrente o bastante para queimar materiais de pessoal ou inflamáveis.



## PERIGO

A menos que uma hot swap seja permitida para a FRU que está sendo substituída, faça o seguinte antes de removê-la: desligue o computador, desconecte todos os cabos de energia das tomadas, remova o pacote de baterias e desconecte quaisquer cabos de interconexão.



## DANGER

Avant de remettre l'ordinateur sous tension après remplacement d'une unité en clientèle, vérifiez que tous les ressorts, vis et autres pièces sont bien en place et bien fixées. Pour ce faire, secouez l'unité et assurez-vous qu'aucun bruit suspect ne se produit. Des pièces métalliques ou des copeaux de métal pourraient causer un court-circuit.



## DANGER

Certaines batteries de secours contiennent du nickel et du cadmium. Ne les démontez pas, ne les rechargez pas, ne les exposez ni au feu ni à l'eau. Ne les mettez pas en court-circuit. Pour les mettre au rebut, conformez-vous à la réglementation en vigueur. Lorsque vous remplacez la pile de sauvegarde ou celle de l'horloge temps réel, veillez à n'utiliser que les modèles cités dans la liste de pièces détachées adéquate. Une batterie ou une pile inappropriée risque de prendre feu ou d'exploser.



## DANGER

La batterie contient du nickel. Ne la démontez pas, ne l'exposez ni au feu ni à l'eau. Ne la mettez pas en court-circuit. Pour la mettre au rebut, conformez-vous à la réglementation en vigueur. Lorsque vous remplacez la batterie, veillez à n'utiliser que les modèles cités dans la liste de pièces détachées adéquate. En effet, une batterie inappropriée risque de prendre feu ou d'exploser.



## DANGER

La pile de sauvegarde contient du lithium. Elle présente des risques d'incendie, d'explosion ou de brûlures graves. Ne la rechargez pas, ne retirez pas son connecteur polarisé et ne la démontez pas. Ne l'exposez pas à une température supérieure à 100°C, ne la faites pas brûler et n'en exposez pas le contenu à l'eau. Mettez la pile au rebut conformément à la réglementation en vigueur. Une pile inappropriée risque de prendre feu ou d'exploser.



## DANGER

Si le panneau d'affichage à cristaux liquides se brise et que vous recevez dans les yeux ou sur les mains une partie du fluide, rincez-les abondamment pendant au moins quinze minutes. Consultez un médecin si des symptômes persistent après le lavage.



## DANGER

Afin d'éviter tout risque de choc électrique, ne retirez pas le cache en plastique protégeant la partie inférieure de la carte d'alimentation.



## DANGER

Bien que le voltage des batteries principales soit peu élevé, le court-circuit ou la mise à la masse d'une batterie peut produire suffisamment de courant pour brûler des matériaux combustibles ou causer des brûlures corporelles graves.



#### DANGER

Si le remplacement à chaud n'est pas autorisé pour l'unité remplaçable sur site que vous remplacez, procédez comme suit avant de retirer l'unité : mettez l'ordinateur hors tension, débranchez tous les cordons d'alimentation des prises de courant, retirez le bloc de batterie et déconnectez tous les câbles d'interconnexion.



#### VORSICHT

Bevor nach einem FRU-Austausch der Computer wieder angeschlossen wird, muß sichergestellt werden, daß keine Schrauben, Federn oder andere Kleinteile fehlen oder im Gehäuse vergessen wurden. Der Computer muß geschüttelt und auf Klappergeräusche geprüft werden. Metallteile oder-splitter können Kurzschlüsse erzeugen.



#### VORSICHT

Die Bereitschaftsbatterie, die sich unter dem Diskettenlaufwerk befindet, kann geringe Mengen Nickel und Cadmium enthalten. Sie darf nur durch die Verkaufsstelle oder den IBM Kundendienst ausgetauscht werden. Sie darf nicht zerlegt, wiederaufgeladen, kurzgeschlossen, oder Feuer oder Wasser ausgesetzt werden. Die Batterie kann schwere Verbrennungen oder Verätzungen verursachen. Bei der Entsorgung die örtlichen Bestimmungen für Sondermüll beachten. Beim Ersetzen der Bereitschafts- oder Systembatterie nur Batterien des Typs verwenden, der in der Ersatzteilliste aufgeführt ist. Der Einsatz falscher Batterien kann zu Entzündung oder Explosion führen.



#### VORSICHT

Akkus enthalten geringe Mengen von Nickel. Sie dürfen nicht zerlegt, wiederaufgeladen, kurzgeschlossen, oder Feuer oder Wasser ausgesetzt werden. Bei der Entsorgung die örtlichen Bestimmungen für Sondermüll beachten. Beim Ersetzen der Batterie nur Batterien des Typs verwenden, der in der Ersatzteilliste aufgeführt ist. Der Einsatz falscher Batterien kann zu Entzündung oder Explosion führen.



#### VORSICHT

Die Systembatterie ist eine Lithiumbatterie. Sie kann sich entzünden, explodieren oder schwere Verbrennungen hervorrufen. Batterien dieses Typs dürfen nicht aufgeladen, zerlegt, über 100°C erhitzt oder verbrannt werden. Auch darf ihr Inhalt nicht mit Wasser in Verbindung gebracht oder der zur richtigen Polung angebrachte Verbindungsstecker entfernt werden. Bei der Entsorgung die örtlichen Bestimmungen für Sondermüll beachten. Beim Ersetzen der Batterie nur Batterien des Typs verwenden, der in der Ersatzteilliste aufgeführt ist. Der Einsatz falscher Batterien kann zu Entzündung oder Explosion führen.



#### VORSICHT

Die Leuchtstoffröhre im LCD-Bildschirm enthält Quecksilber. Bei der Entsorgung die örtlichen Bestimmungen für Sondermüll beachten. Der LCD-Bildschirm besteht aus Glas und kann zerbrechen, wenn er unsachgemäß behandelt wird oder der Computer auf den Boden fällt. Wenn der Bildschirm beschädigt ist und die darin befindliche Flüssigkeit in Kontakt mit Haut und Augen gerät, sollten die betroffenen Stellen mindestens 15 Minuten mit Wasser abgespült und bei Beschwerden anschließend ein Arzt aufgesucht werden.



#### VORSICHT

Aus Sicherheitsgründen die Kunststoffabdeckung, die den unteren Teil der Spannungswandlerplatine umgibt, nicht entfernen.



#### VORSICHT

Obwohl Hauptbatterien eine niedrige Spannung haben, können sie doch bei Kurzschluß oder Erdung genug Strom abgeben, um brennbare Materialien zu entzünden oder Verletzungen bei Personen hervorzurufen.



#### VORSICHT

Wenn ein Austausch der FRU bei laufendem Betrieb nicht erlaubt ist, gehen Sie beim Austausch der FRU wie folgt vor: Schalten Sie den Computer aus, ziehen Sie alle Netzkabel von den Netzsteckdosen ab, entfernen Sie den Akku und ziehen Sie alle miteinander verbundenen Kabel ab.



סכנה

לפני הפעלת המחשב לאחר החלפת FRU יש לוודא שכל הברגים, הקפיצים, וחלקים קטנים אחרים נמצאים במקומם ואינם חופשיים לזוז בתוך המחשב. כדי לוודא זאת, יש לטלטל את המחשב ולחקשיב לגילוי קולות שקשוק. חלקי או שבבי מתכת עלולים לגרום לקצרים חשמליים.



סכנה

סוללות המתנה מסוימות מכילות כמות קטנה של ניקל וקדמיום. אין לפרק סוללת המתנה, לטעון אותה מחדש, להשליך אותה לאש או למים או לקצר אותה. יש לסלק את הסוללה כנדרש על ידי התקנות והחוקים המקומיים. יש להשתמש רק בסוללה המופיעה ברשימת החלקים המתאימה. שימוש בסוללה לא מתאימה עלול לגרום להצתה או התפוצצות של הסוללה.



סכנה

מארז הסוללה מכיל כמות קטנה של ניקל וקדמיום. אין לפרק את מארז הסוללה, להשליך אותו לאש או למים או לקצר אותו. יש לסלק את מארז הסוללה כנדרש על ידי התקנות והחוקים המקומיים. יש להשתמש רק בסוללה המופיעה ברשימת החלקים המתאימה בזמן החלפת מארז הסוללה. שימוש בסוללה לא מתאימה עלול לגרום להצתה או התפוצצות של הסוללה.



סכנה

סוללת הליתיום עלולה לגרום לשריפה, להתפוצצות או לכוויות קשות. אין לטעון אותה מחדש, לסלק את המחבר המקוטב שלה, לפרק אותה או לחמם אותה לטמפרטורה העולה על 100 מעלות צלזיוס. אין לשרוף את הסוללה ואין לחשוף את תוכן התא למים. יש לסלק את הסוללה כנדרש בתקנות ובחוקים המקומיים. יש להשתמש רק בסוללה המופיעה ברשימת החלקים המתאימים. שימוש בסוללה אחרת עלול לגרום לסכנת שריפה או התפוצצות.



סכנה

אם מסך הגביש הנזולי (LCD) נשבר והנזול מתוך המסך בא במגע עם עיניכם או יריכם, שטפו את האזורים הנגועים מיד במים במשך 15 דקות לפחות. פנו לקבלת עזרה רפואית אם תסמינים הנובעים מחמצע עם הנזול נמשכים לאחר הטיפול.



סכנה

כדי למנוע התחשמלות, אין להסיר את מכסה הפלסטיק המגן על חלקו התחתון של הכרטיס החמור.



סכנה

אף שהסוללות הראשיות הן בעלות מותח נמוך, סוללה מקוצרת או מוארכת עלולה להפיק זרם מספיק לגרימת כוויות או להצתת חומרים דליקים.



סכנה

אלא אם כן מותרת 'החלפה חמה' של ה-FRU המוחלף, פעלו כדלהלן לפני חסרתו: כבו את המחשב, נתקו את כל כבלי החשמל מחשקעים, הוציאו את מארז הסוללות ונתקו את כל הכבלים מחוברים.



## 危険

FRUの交換後、ThinkPadの電源を入れる前に、ねじ、パネ、その他の小さな部品がすべて正しい位置にあり、またThinkPadの内部で緩んでいないことを確認してください。  
これを確認するには、ThinkPadを振って、カチャカチャと音がしないか確かめます。金属部品や金属破片はショートの原因になることがあります。



## 危険

予備バッテリーの中には少量のニッケルとカドミウムが含まれているものがあります。したがって、予備バッテリーの分解、再充電、火または水の中への投棄、またはショートさせることは決して行わないでください。バッテリーを廃棄する場合は地方自治体の条例に従ってください。適切なパーツ・リストにあるバッテリーだけを使用してください。誤ったバッテリーを使用すると、バッテリーが発火したり、爆発したりすることがあります。



## 危険

バッテリー・パックには少量のニッケルが含まれています。バッテリー・パックを分解したり、火または水の中に投げ込んだり、ショートさせないでください。バッテリー・パックの廃棄にあたっては、地方自治体の条例または規則に従ってください。バッテリー・パックを交換するときは、適切なパーツ・リストにあるバッテリーだけを使用してください。誤ったバッテリーを使用すると、バッテリーが発火したり、爆発したりすることがあります。



## 危険

リチウム・バッテリーは、火災、爆発、または重症のやけどを引き起こすことがあります。バックアップ・バッテリーの充電、その極性コネクタの取り外し、バッテリー本体の分解、100°C (212°F)以上への加熱、焼却、電池の中身を水に浸すことはしないでください。バッテリーを廃棄する場合は地方自治体の条例に従ってください。適切なパーツ・リストにあるバッテリーだけを使用してください。誤ったバッテリーを使用すると、バッテリーが発火したり、爆発したりすることがあります。



## 危険

LCDが破損し、LCDの中の液体が目に入ったり、手に触れたりした場合は、液体が触れた部分を少なくとも15分間洗い流してください。洗い流した後に、液体によって何らかの症状が現れた場合は、医師の治療を受けてください。



## 危険

感電を防ぐため、インバーター・カードの下部を保護しているプラスチック・カバーを外さないでください。



## 危険

メイン・バッテリーの電圧は低くても、ショートしたり、接地したバッテリーが、作業者にやけどを負わせたり、可燃物を燃やすだけの電流を発生させる場合があります。



## 危険

交換しようとしている FRU がホット・スワップに対応していない場合、それを取り外す前に、コンピューターの電源をオフにし、すべての電源コードをコンセントから抜き、バッテリー・バックを取り外して、相互接続しているケーブルをすべて切り離してください。



## 위험

FRU를 교체하고 나서 컴퓨터 전원을 켜기 전에 모든 나사, 스프링 및 기타 작은 부품들이 올바른 위치에 있는지, 컴퓨터 내부에 단단하게 연결되어 있는지 확인하십시오. 컴퓨터를 흔들어 탈락거리는 소리가 나지 않는지 확인하십시오. 금속 부품 또는 금속 조각은 누전을 일으킬 수 있습니다.



## 위험

일부 보조 배터리에는 소량의 니켈 및 카드뮴이 포함되어 있습니다. 보조 배터리를 분해하거나, 다시 충전하거나, 불 또는 물에 던지거나, 단락시키지 마십시오. 배터리 팩을 폐기할 때에는 해당 지역의 법률 규정을 따르십시오. 배터리 팩을 교체할 때에는 올바른 배터리만 사용하십시오. 올바르지 않은 배터리를 사용하면 배터리가 발화되거나 폭발할 수 있습니다.



## 위험

배터리 팩에는 소량의 니켈이 포함되어 있습니다. 배터리 팩을 분해하거나, 불 또는 물에 던지거나, 단락시키지 마십시오. 배터리 팩을 폐기할 때에는 해당 지역의 법률 규정을 따르십시오. 배터리 팩을 교체할 때에는 올바른 배터리만 사용하십시오. 올바르지 않은 배터리를 사용하면 배터리가 발화되거나 폭발할 수 있습니다.



## 위험

리튬 배터리는 화재, 폭발 또는 심각한 화상을 일으킬 수 있습니다. 리튬 배터리를 다시 충전하거나, 극성 커넥터를 제거하거나, 분해하거나, 100C(212F) 이상으로 가열하거나, 소각하거나, 전지 내용물을 물에 노출시키지 마십시오. 배터리를 폐기할 때에는 해당 지역을 법률 규정을 따르십시오. 올바른 배터리만 사용하십시오. 올바르지 않은 배터리를 사용하면 배터리가 발화되거나 폭발할 수 있습니다.





위험

LCD가 파손되어 LCD 내부의 액체가 눈에 들어가거나 손에 묻으면 즉시 깨끗한 물로 15분 이상 닦아 내십시오. 씻은 후에 조금이라도 이상을 느끼면 즉시 병원에 가서 의사의 진찰을 받아야 합니다.



위험

전기적 위험을 방지하려면 인버터 카드의 아래 부분을 보호하는 플라스틱 덮개를 제거하지 마십시오.



위험

기본 배터리의 전압은 낮지만, 단락되거나 접지된 배터리는 화상을 입히기에 충분한 전류와 가연성 물질을 발생시킬 수 있습니다.



위험

FRU 교체 시 Hot Swap이 지원되지 않는 경우, FRU를 제거하기 전에 컴퓨터의 전원을 끄고, 전기 콘센트에서 전원 코드를 분리하고, 배터리를 제거한 후, 연결된 모든 케이블을 분리하십시오.



PELIGRO

Antes de encender el sistema despues de sustituir una FRU, compruebe que todos los tornillos, muelles y demás piezas pequeñas se encuentran en su sitio y no se encuentran sueltas dentro del sistema. Compruébelo agitando el sistema y escuchando los posibles ruidos que provocarían. Las piezas metálicas pueden causar cortocircuitos eléctricos.



PELIGRO

Algunas baterías de reserva contienen una pequeña cantidad de níquel y cadmio. No las desmonte, ni recargue, ni las eche al fuego o al agua ni las cortocircuite. Deséchelas tal como dispone la normativa local. Utilice sólo baterías que se encuentren en la lista de piezas. La utilización de una batería no apropiada puede provocar la ignición o explosión de la misma.



PELIGRO

Las baterías contienen pequeñas cantidades de níquel. No las desmonte, ni recargue, ni las eche al fuego o al agua ni las cortocircuite. Deséchelas tal como dispone la normativa local. Utilice sólo baterías que se encuentren en la lista de piezas al sustituir la batería. La utilización de una batería no apropiada puede provocar la ignición o explosión de la misma.



**PELIGRO**

La batería de repuesto es una batería de litio y puede provocar incendios, explosiones o quemaduras graves. No la recargue, ni quite el conector polarizado, ni la desmonte, ni caliente por encima de los 100°C (212°F), ni la incinere ni exponga el contenido de sus celdas al agua. Deséchela tal como dispone la normativa local.



**PELIGRO**

Si la LCD se rompe y el fluido de su interior entra en contacto con sus ojos o sus manos, lave inmediatamente las áreas afectadas con agua durante 15 minutos como mínimo. Obtenga atención médica si se presenta algún síntoma del fluido después de lavarse.



**PELIGRO**

Para evitar descargas, no quite la cubierta de plástico que rodea la parte baja de la tarjeta invertida.



**PELIGRO**

Aunque las baterías principales tienen un voltaje bajo, una batería cortocircuitada o con contacto a tierra puede producir la corriente suficiente como para quemar material combustible o provocar quemaduras en el personal.



**PELIGRO**

Salvo que se permita el intercambio en caliente para la unidad sustituible localmente, realice lo siguiente antes de extraerla: apague el sistema, desconecte todos los cables de alimentación de las tomas de alimentación eléctrica, extraiga la batería y desconecte los cables de interconexión.



危險

完成 FRU 更換之後，在開啟電腦的電源之前，請確定所有螺絲、彈簧及其他小零件都已歸位，沒有遺留在電腦內部。  
若要確認這一點，請搖晃電腦，聽聽看是否有卡嗒的聲響。  
金屬零件或機錶的火花會造成電線短路。



危險

部分備用電池含有微量的鎳和鎘。請勿拆開備用電池、再充電、丟入火或水中，或使其形成短路。請按照當地法令或規定來棄置電池。  
僅限使用零件清單中的電池。使用不適當的電池會導致電池起火或爆炸。



危險

電池套件含有微量的鎳。請勿拆開電池套件、丟入火或水中，或使其形成短路。請按照當地法令或規定來棄置電池套件。  
更換電池套件時，僅限使用零件清單中的電池。使用不適當的電池會導致電池起火或爆炸。



危險

鋰電池會導致起火、爆炸或嚴重燒傷。請勿再充電、拔除其電極接頭、拆開、加熱超過 100°C (212°F)、焚燒，或讓電池組成物浸到水。請按照當地法令或規定來棄置電池。  
僅限使用零件清單中的電池。使用不適當的電池會導致電池起火或爆炸。



危險

如果 LCD 破裂導致 LCD 流出的液體沾到您的眼睛或手，請立即以清水沖洗沾染部位至少 15 分鐘。如果在清洗後出現該液體所造成的任何症狀，請就醫治療。



危險

為避免電擊，請勿拆下轉換卡下面的塑膠護蓋。



危險

雖然主電池的電壓很低，但短路或接地電池所產生的電流，仍足以使人燒傷或使可燃物質起火。



危險

除非 FRU 允許以熱抽換來替換，否則請依下列方式將其移除：將電腦關機，拔除插座上所有電源線，移除電池包，並拔開任何交互連接的線材。

---

## Chapter 2. Important service information

This chapter introduces following important service information that applies to all machine types supported by this manual:

- “Strategy for replacing FRUs” on page 19
  - “Strategy for replacing a hard disk drive or a solid-state drive” on page 19
  - “Important notice for replacing a system board” on page 20
  - “FRU identification” on page 20

### **Important:**

- If the computer is equipped with both a hard disk drive and an M.2 solid-state drive, do not use the M.2 solid-state drive as a bootable device. The M.2 solid-state drive is designed and developed for “cache” function purpose only.
- Advise customers to contact the Lenovo® Customer Support Center if they need any assistance in obtaining or installing any software fixes, drivers, and Unified Extensible Firmware Interface basic input output system (UEFI BIOS) downloads. Telephone numbers for Lenovo Support are available at: <http://www.lenovo.com/support/phone>
- System Disassembly/Reassembly videos that show the FRU removals or replacements for the Lenovo authorized service technicians are available in the following support site: <http://www.lenovoservicetraining.com/ion/>

---

## Strategy for replacing FRUs

### **Before replacing parts:**

Ensure that all software fixes, drivers, and UEFI BIOS downloads are installed before replacing any FRUs listed in this manual.

After a system board is replaced, ensure that the latest UEFI BIOS is loaded to the system board before completing the service action.

To download software fixes, drivers, and UEFI BIOS, go to [http://support.lenovo.com/en\\_US/downloads/detail.page?LegacyDocID=DRVR-MATRIX](http://support.lenovo.com/en_US/downloads/detail.page?LegacyDocID=DRVR-MATRIX) and follow the instructions on the screen.

Use the following strategy to prevent unnecessary expense for replacing and servicing FRUs:

- If you are instructed to replace a FRU but the replacement does not correct the problem, reinstall the original FRU before you continue.
- Some computers have both a processor board and a system board. If you are instructed to replace either the processor board or the system board, and replacing one of them does not correct the problem, reinstall that board, and then replace the other one.
- If an adapter or a device consists of more than one FRU, any of the FRUs might be the cause of the error. Before replacing the adapter or device, remove the FRUs, one by one, to see if the symptoms change. Replace only the FRU that changed the symptoms.

## Strategy for replacing a hard disk drive or a solid-state drive

Always try to run a low-level format before replacing a hard disk drive or a solid-state drive. This will cause all customer data on the drive to be lost. Be sure that the customer has a current backup of the data before doing this task.

**Attention:** The drive startup sequence in the computer you are servicing may have been changed. Be extremely careful during write operations such as copying, saving, or formatting. If you select an incorrect drive, data or programs can be overwritten.

## Important notice for replacing a system board

Some components mounted on a system board are very sensitive. Improper handling of a system board can cause damage to those components, and may cause a system malfunction.

**Attention:** When handling a system board:

- Do not drop a system board or apply any excessive force to it.
- Avoid rough handling of any kind.
- Avoid bending a system board and hard pushing to prevent cracking at each ball-grid-array (BGA) chipset.

## FRU identification

Use Lenovo eSupport to identify major FRUs, FRU part numbers, and FRU descriptions for a product at an MT - serial number level. Examples of major FRUs are hard disk drive, system board, liquid crystal display (LCD), and memory module.

To identify the major FRUs for a product, do the following:

1. Go to:  
<http://www.lenovo.com/support>
2. Click **Warranty & Services**.
3. Click **Check Warranty Status**.
4. On the Warranty Status Lookup page, click **Parts Lookup**.
5. Type your machine type and serial number, and then click **Submit**.

eSupport also can be used to view the general FRU list for a product.

To get the general FRU list for a product, do the following:

1. Go to:  
<http://www.lenovo.com/support>
2. Click **Parts**.
3. Follow the instructions on the screen to select product.
4. Click **Products and Parts Detail**.
5. On the PRODUCT AND PARTS DETAIL page, click the **Parts Detail** tab to view the FRU list.

**Note:** The FRU list is a general list of components and does not contain specific model information.

---

## Chapter 3. General checkout

This chapter introduces following information:

- “What to do first” on page 21
- “Power system checkout” on page 22

Before you go to the checkout guide, be sure to read the following important notes.

### Important notes:

- **Only certified trained personnel should service the computer.**
- **Before replacing any FRU, read the entire page on removing and replacing FRUs.**
- **When you replace FRUs, carefully remove and retain screws so they can be reused.**
- **Be extremely careful during such write operations as copying, saving, or formatting.** The sequence of the drives in the computer that you are servicing might have been altered. If you select an incorrect drive, data or programs might be overwritten.
- **Replace a FRU only with another FRU of the correct model.** When you replace a FRU, ensure that the model of the machine and the FRU part number are correct by referring to the FRU parts list.
- **A FRU should not be replaced because of a single, unreproducible failure.** Single failures can occur for a variety of reasons that have nothing to do with a hardware defect, such as cosmic radiation, electrostatic discharge, or software errors. Consider replacing a FRU only when a problem recurs. If you suspect that a FRU is defective, clear the error log and run the test again. If the error does not recur, do not replace the FRU.
- **Be careful not to replace a nondefective FRU.**

---

## What to do first

When you return a FRU, you must include the following information in the parts exchange form or parts return form that you attach to it:

1. Name and phone number of service technician
2. Date of service
3. Date on which the machine failed
4. Date of purchase
5. Failure symptoms, error codes appearing on the display, and beep symptoms
6. Procedure index and page number in which the failing FRU was detected
7. Failing FRU name and part number
8. Machine type, model number, and serial number
9. Customer's name and address

**Note:** During the warranty period, the customer may be responsible for repair costs if the computer damage was caused by misuse, accident, modification, unsuitable physical or operating environment, or improper maintenance by the customer. Following is a list of some common items that are not covered under warranty and some symptoms that might indicate that the system was subjected to stress beyond normal use.

Before checking problems with the computer, determine whether the damage is covered under the warranty by referring to the following list:

### The following are not covered under warranty:

- LCD panel cracked from the application of excessive force or from being dropped
- Scratched (cosmetic) parts
- Distortion, deformation, or discoloration of the cosmetic parts

- Plastic parts, latches, pins, or connectors that have been cracked or broken by excessive force
- Damage caused by liquid spilled into the system
- Damage caused by the improper insertion of a personal-computer card (PC card) or the installation of an incompatible card
- Improper disc insertion or use of an external optical drive
- Fuses blown by attachment of a non-supported device
- Forgotten computer password (making the computer unusable)
- Sticky keys caused by spilling a liquid onto the keyboard
- Use of an incorrect ac power adapter on laptop products

**The following symptoms might indicate damage caused by non-warranted activities:**

- Missing parts might be a symptom of unauthorized service or modification.
- Check for obvious damage to a hard disk drive. If the spindle of a hard disk drive becomes noisy, the hard disk drive might have been dropped or subject to excessive force.

## Power system checkout

To verify if a battery pack or an ac power adapter is functional, do the following:

1. Turn off the computer.
2. Connect the ac power adapter.
3. Turn on the computer. If the computer can be turned on, it means that either the battery pack or the ac power adapter is functional.
4. Insert a straightened paper clip into the novo button to reset the computer. If the computer is still powered on, it means that the ac power adapter is functional.
5. Turn off the computer.
6. Disconnect the ac power adapter and turn on the computer. If the computer can be turned on, it means that the battery pack is functional.

If you suspect a power problem, see the appropriate one of the following power supply checkouts:

- “Checking the ac power adapter” on page 22
- “Checking the external battery pack and the operational charging” on page 23

## Checking the ac power adapter

You are here because the computer fails only when the ac power adapter is used.

- If the power problem occurs only when the docking station or the port replicator is used, replace the docking station or the port replicator.
- If the power-on indicator does not turn on, check the power cord of the AC adapter for correct continuity and installation.
- If the computer does not charge during operation, go to “Checking the external battery pack and the operational charging” on page 23.

To check the ac power adapter, do the following:

1. Unplug the ac power adapter cable from the computer.
2. Measure the output voltage at the plug of the ac power adapter cable. See the following illustration:

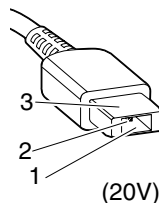

Pin	Voltage (V dc)
1	+20
2	0
3	Ground



**Note:** Output voltage of pin 2 of the ac power adapter might differ from the one you are servicing.

3. If the voltage is not correct, replace the ac power adapter.
4. If the voltage is acceptable, replace the system board.

**Note:** Noise from the ac power adapter does not always indicate a defect.

## Checking the external battery pack and the operational charging

### Checking the external battery pack

This computer supports only batteries specially designed for this specific system and manufactured by Lenovo or an authorized builder. The system does not support unauthorized batteries or batteries designed for other systems. If an unauthorized battery or a battery designed for another systems is installed, the system will not charge.

**Attention:** Lenovo has no responsibility for the performance or safety of unauthorized batteries, and provides no warranties for failures or damage arising out of their use.

The battery status icon in the Windows notification area displays the percentage of the battery power remained.

To check for detailed battery status information, do the following:

- For Windows 7: Open the Power Manager program and click the **Battery** tab.
- For Windows 8 and Windows 8.1: Open the Lenovo Settings program and click **Power**.

**Note:** If the external battery pack becomes hot, it may not be able to charge. Remove it from the computer and leave it at room temperature for a while. After it cools down, reinstall and recharge it.

### Checking the operational charging

To check whether the battery pack charges properly during operation, do the following:

1. Discharge the battery pack until the remained battery power is less than 50%.
2. Connect the computer to ac power to charge the battery pack. If the battery status icon in the Windows notification area indicates that the battery pack is not charging, remove the battery pack and let it return to room temperature.
3. Reinstall the battery pack. If the battery pack is still not charging, replace the battery pack.
4. Check the battery status icon again. If the same error still exists, replace the system board.



---

## Chapter 4. Related service information

This chapter presents following information:

- “Restoring the factory contents by using OneKey Recovery” on page 25
- “Power management” on page 25

---

### Restoring the factory contents by using OneKey Recovery

#### Restore of factory default

The Lenovo E4030/E4070 computers come with pre-installed OneKey Recovery System. In order to save application files and the initial backed up files of the system, the hard disk in a Lenovo computer includes a hidden partition when it is shipped. If you need to restore the system to the point of your first boot up, just enter Lenovo OneKey Recovery System and run **System Recovery**. For details of OneKey Recovery System, see the User Guide for Lenovo OneKey Recovery system.

**Note:** This will delete all the new data on the system partition (C drive), which is not recoverable. Make sure to back up your critical data before you perform this action.

When you use the recovery discs to boot your computer, the system will enter the user interface for system recovery automatically. Please follow the prompt to insert the backup discs to complete the whole recovery process.

**Note:** The recovery process might take up to 2 hours.

---

### Power management

To reduce power consumption, the computer has three power management modes: screen blank, sleep, and hibernation.

#### Screen blank mode (for the Windows 7 operating system only)

If the time set on the “Turn off monitor” timer in the operating system expires, the LCD backlight turns off.

To put the computer into screen blank mode, do the following:

1. Right-click the battery status indicator on the taskbar.
2. Select **Power off display**.

To end screen blank mode and resume normal operation, press any key.

#### Sleep mode

When the computer enters sleep mode, the following events occur in addition to what occurs in screen blank mode:

- The LCD is powered off.
- The hard disk drive or solid-state drive is powered off.
- The microprocessor stops.

To put your computer into sleep mode, press Fn+F1 or do the following:

- For Windows 7: Click the arrow beside the **Shut down** icon, and then select **Sleep**. To return from sleep mode, press any key.

- For Windows 8 and Windows 8.1: Move the cursor to the bottom-right corner of the screen to display the charms. Then click **Settings → Power → Sleep**.

To return to normal operation, press any key.

In certain circumstances, the computer goes into sleep mode automatically:

- After a period of inactivity specified in power plan settings
- When the battery power is low

## Hibernation mode

In hibernation mode, the following occurs:

- The system status, random access memory (RAM), video random access memory (VRAM), and setup data are stored on the hard disk drive or solid-state drive.
- The system is powered off.

**Note:** If the computer enters the hibernation mode while it is docked to the docking station or the port replicator, do not undock it before resuming normal operation. If you do undock it and then try to resume normal operation, you will get an error message, and you will have to restart the system.

If you have defined one of the following actions as the event that causes the system to go into hibernation mode, perform that action.

- Closing the lid.
- Pressing the power button.

Also, the computer goes into hibernation mode automatically after a period of inactivity specified in power plan settings.

When the power is turned on, the computer returns from hibernation mode and resumes operation. The hibernation file in the boot record on the hard disk drive or solid-state drive is read, and system status is restored from the hard disk drive or solid-state drive.

---

## Chapter 5. Passwords

As many as three passwords may be needed for any Lenovo computer: the power-on password (POP), the hard disk password (HDP), and the administrator password.

If any of these passwords has been set, a prompt for it appears on the screen whenever the computer is turned on. The computer does not start until the password is entered.

---

### Power-on password

A power-on password protects the system from being powered on by an unauthorized person. The password must be entered before an operating system can be started.

---

### Hard disk password

There are two kinds of hard disk passwords:

- User hard disk password - for the user
- Master hard disk password - for the system administrator, who can use it to get access to the hard disk even if the user has changed the user hard disk password

**Note:** There are two modes for the hard disk password: **User only** and **Master + User**. The **Master + User** mode requires two hard disk passwords; the system administrator enters both in the same operation. The system administrator then provides the user hard disk password to the system user.

**Attention:** If the user hard disk password has been forgotten, check whether a master hard disk password has been set. If it has, it can be used for access to the hard disk drive. If no master hard disk password is available, neither Lenovo nor Lenovo authorized service technicians provide any services to reset either the user or the master hard disk password, or to recover data from the hard disk drive. The hard disk drive can be replaced for a scheduled fee.

---

### Administrator password

Administrator password controls the access of the whole setup utility. Only Administrator password was set then User password can be set. If Administrator password was cleared, the User password was cleared too.

**Attention:** If the administrator password has been forgotten and cannot be made available to the service technician, there is no service procedure to reset the password. The system board must be replaced for a scheduled fee.



## Chapter 6. Status indicators

This chapter presents the status indicators that show the status of the computer.

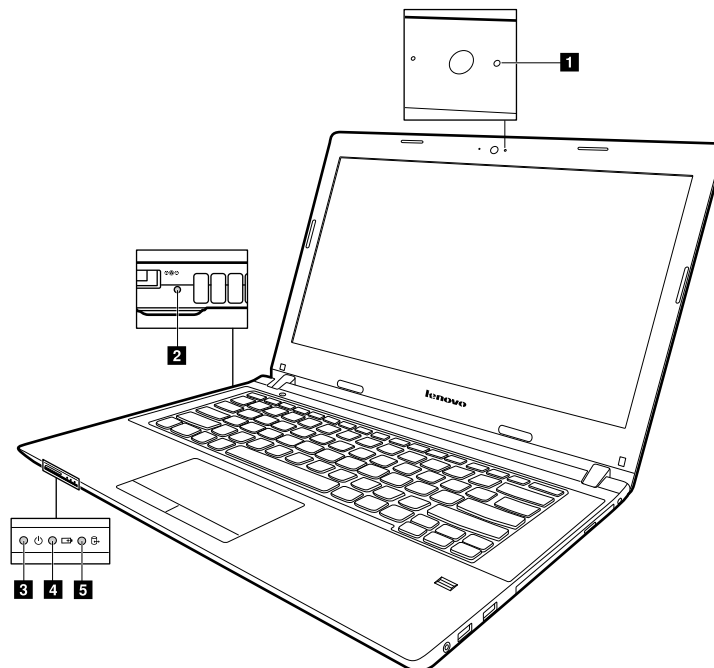

Table 1. Status indicators

Indicator	Meaning
<b>1</b> Camera status indicator	<b>On:</b> The camera is in use.
<b>2</b> dc - in indicator	<b>On:</b> The computer is plugged into a working electrical outlet.
<b>3</b> Power indicator	<b>On:</b> The computer is powered on. <b>On:</b> The computer is powered off or in hibernation mode. <b>Blinks:</b> The computer is in sleep mode.
<b>4</b> Battery Status indicator	<b>Solid green:</b> The battery charge level is between 80% and 100%, or the battery discharge level is between 20% and 100%. <b>Slow - blinking green:</b> The battery charge level is between 20% and 80%, and charging is continuing. <b>Slow - blinking amber:</b> The battery charge level is between 5% and 20%, and charging is continuing. <b>Solid amber:</b> The battery has between 5% and 20% charge. <b>Fast- blinking amber:</b> The battery charge or discharge level is 5% or less. <b>Off:</b> The battery is detached or the computer is turned off.
<b>5</b> Device access status indicator	<b>On:</b> The hard disk drive or the optical drive is reading or writing data. <b>Off:</b> The computer is off or in hibernation mode.





---

## Chapter 7. Function keys

The following table describes the functions of function keys and key combinations.

Table 2. Function keys

Function key and key combination	Description
Fn+F1	Enter sleep mode.
Fn+F2	Turns on/off LCD backlight.
Fn+F3	Switches display devices.
Fn+F4	Enables/Disables camera.
Fn+F5	For Windows 7: Change wireless settings. For Windows 8.1: Enable/Disables airplane mode.
Fn+F6	Mute/Unmutes sound.
Fn+F7	Enables/Disables microphone.
Fn+F8	Enables/Disables touch pad.
Fn+F9	For Windows 7: Opens <b>Control Panel</b> . For Windows 8.1: Opens the <b>Settings</b> charm.
F10	For Windows 7: Opens <b>Windows Search</b> . For Windows 8.1: Opens the <b>Search</b> charm.
F11	Views the programs that you have opened.
F12	For Windows 7: Opens <b>Computer</b> . For Windows 8.1: Views all the programs.



---

## Chapter 8. Locations

This chapter introduces the locations of the hardware components on your computer.

---

### Locating FRUs and CRUs

This topic introduces the following service parts:

- “Major FRUs and CRUs” on page 34
- “LCD FRUs” on page 40
- “Miscellaneous parts and other FRUs” on page 41

#### Notes:

- Each FRU is available for all types or models, unless otherwise specified.
- **CRU statement for customers:**

You can resolve some problems with your product with a replacement part you can install yourself, called a “Customer Replaceable Unit” or “CRU.” Some CRUs are designated as self-service CRUs and others are designated as optional-service CRUs. *Installation of self-service CRUs is your responsibility. For optional-service CRUs, you can either install the CRU yourself or you can request that a Service Provider install the CRU according to the warranty service for your product.* If you intend on installing the CRU, Lenovo will ship the CRU to you. CRU information and replacement instructions are shipped with your product and are available from Lenovo at any time upon request. You can find a list of CRUs for your product in this *Hardware Maintenance Manual*. An electronic version of this manual can be found at <http://www.lenovo.com/UserManuals>. Follow the on-screen instructions to find the manual for your product. You might be required to return the defective part that is replaced by the CRU. When return is required: (1) return instructions, a prepaid shipping label, and a container will be included with the replacement CRU; and (2) you might be charged for the replacement CRU if Lenovo does not receive the defective CRU within thirty (30) days of your receipt of the replacement CRU. See your Lenovo Limited Warranty documentation for full details.

Lenovo computers contain the following types of CRUs:

- **Self-service CRUs:** These CRUs unplug or are held by no more than two screws. Examples of these types of CRUs include the ac power adapter, power cord, and battery. Other self-service CRUs depending on product design might include the memory module, wireless card, keyboard, and palm rest with finger print reader and touch pad.
- **Optional-service CRUs:** These CRUs are isolated parts within the computer that are concealed by an access panel that is typically secured by more than two screws. Once the access panel is removed, the specific CRU is visible.

## Major FRUs and CRUs

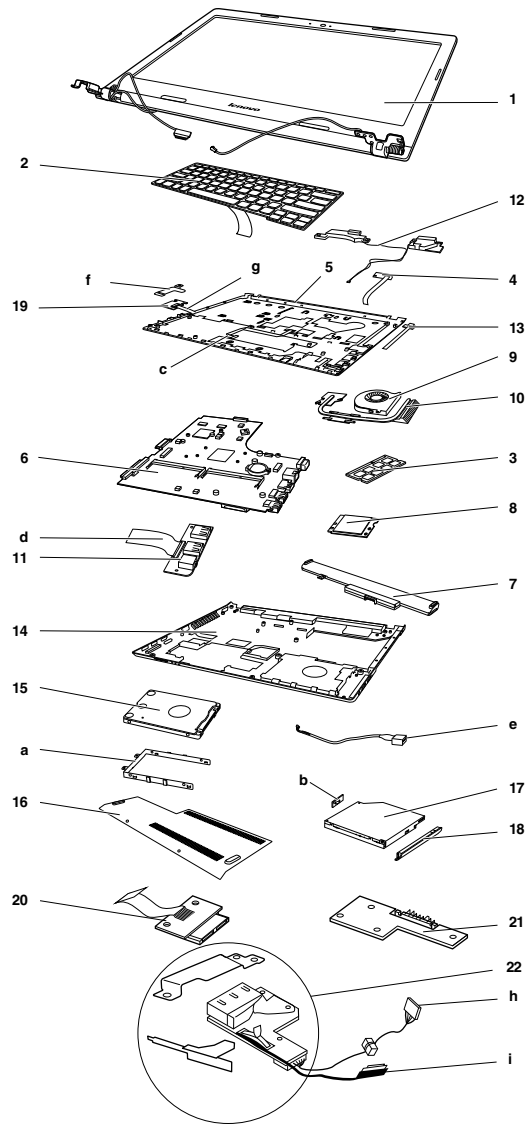

Table 3. Major FRUs

No.	FRU parts	FRU descriptions	Self-service CRU	Optional-service CRU	FRU No.
1	LCD unit	LCD unit	No	No	
2	Keyboard	Keyboard bezel assembly	No	Yes	
3	Memory Module	Memory Module: M471B5674QH0-YK0	Yes	No	11202451
3	Memory Module	Memory Module: HMT425S6AFR6A-PB 2GB DDR3L 1600	Yes	No	11201299
3	Memory Module	Memory Module: RMT3170MK58F8F-1600 2GB DDR3L 1600	Yes	No	11202301
3	Memory Module	Memory Module: RMT3190ME76F8F-1600 2GB	Yes	No	5M30G04992

Table 3. Major FRUs (continued)

No.	FRU parts	FRU descriptions	Self-service CRU	Optional-service CRU	FRU No.
3	Memory Module	Memory Module: DDR3L 1600 4GB M471B5173DB0-YK0 25nm 4GB DDR3L 1600	Yes	No	11202081
3	Memory Module	Memory Module: DDR3L 1600 4GB SK HMT451S6BFR8A-PB/RD 4GB DDR3L 1600	Yes	No	11202706
3	Memory Module	Memory Module: DDR3L 1600 4GB RMT3170ME68F9F-1600 4GB DDR3L 1600(MC)	Yes	No	11202302
3	Memory Module	Memory Module: DDR3L 1600 4GB MC MT8KTF51264HZ-1G6E1 4GB DDR3L 1600	Yes	No	11202125
3	Memory Module	Memory Module: DDR3L 1600 8GB M471B1G73DB0-YK0 25nm 8GB DDR3L 1600	Yes	No	11202082
3	Memory Module	Memory Module: DDR3L 1600 8GB SK HMT41GS6BFR8A-PB/RD 8GB DDR3L 1600	Yes	No	11202707
3	Memory Module	Memory Module: DDR3L 1600 8GB RMT3160ME68FAF-1600 8GB DDR3L 1600	Yes	No	11202450
3	Memory Module	Memory Module: DDR3L 1600 8GB Mic MT16KTF1G64HZ-1G6E1 DDR3L 1600	Yes	No	11201304
4	Power board	Power Board C E50-70	No	No	5C50H44839
5	Upper case	Upper CoverCE50-70W/TP/TPCB FP	No	No	5CB0H44855
5	Upper case	Upper CoverCE50-70W/TP/TPCB NFP	No	No	5CB0H44847
6	System board	MB C E50-80 NOK 2G 5500 G DOC	No	No	5B20H56221
6	System board	MB C E50-80 W8P 2G 5500 G DOC	No	No	5B20H56218
6	System board	MB C E50-80 W8S 2G 5500 G DOC	No	No	5B20H56206
6	System board	MB C E50-80 NOK 2G 5500 G NDOC	No	No	5B20H56198
6	System board	MB C E50-80 W8P 2G 5500 G NDOC	No	No	5B20H56189
6	System board	MB C E50-80 W8S 2G 5500 G NDOC	No	No	5B20H56184
6	System board	MB C E50-80 NOK 1G 5500 G DOC	No	No	5B20H56177
6	System board	MB C E50-80 W8P 1G 5500 G DOC	No	No	5B20H56260
6	System board	MB C E50-80 W8S 1G 5500 G DOC	No	No	5B20H56251
6	System board	MB C E50-80 NOK 1G 5500 G NDOC	No	No	5B20H56243
6	System board	MB C E50-80 W8P 1G 5500 G NDOC	No	No	5B20H56234
6	System board	MB C E50-80 W8S 1G 5500 G NDOC	No	No	5B20H56223
6	System board	MB C E50-80 NOK UMA 5500 G DOC	No	No	5B20H56212
6	System board	MB C E50-80 W8P UMA 5500 G DOC	No	No	5B20H56232
6	System board	MB C E50-80 W8S UMA 5500 G DOC	No	No	5B20H56222

Table 3. Major FRUs (continued)

No.	FRU parts	FRU descriptions	Self-service CRU	Optional-service CRU	FRU No.
6	System board	MB C E50-80 NOK UMA 5500 G NDOC	No	No	5B20H56211
6	System board	MB C E50-80 W8P UMA 5500 G NDOC	No	No	5B20H56202
6	System board	MB C E50-80 W8S UMA 5500 G NDOC	No	No	5B20H56197
6	System board	MB C E50-80 NOK 2G 5200 G DOC	No	No	5B20H56188
6	System board	MB C E50-80 W8P 2G 5200 G DOC	No	No	5B20H56181
6	System board	MB C E50-80 W8S 2G 5200 G DOC	No	No	5B20H56265
6	System board	MB C E50-80 NOK 2G 5200 G NDOC	No	No	5B20H56257
6	System board	MB C E50-80 W8P 2G 5200 G NDOC	No	No	5B20H56248
6	System board	MB C E50-80 W8S 2G 5200 G NDOC	No	No	5B20H56239
6	System board	MB C E50-80 NOK 1G 5200 G DOC	No	No	5B20H56229
6	System board	MB C E50-80 W8P 1G 5200 G DOC	No	No	5B20H56261
6	System board	MB C E50-80 W8S 1G 5200 G DOC	No	No	5B20H56252
6	System board	MB C E50-80 NOK 1G 5200 G NDOC	No	No	5B20H56244
6	System board	MB C E50-80 W8P 1G 5200 G NDOC	No	No	5B20H56235
6	System board	MB C E50-80 W8S 1G 5200 G NDOC	No	No	5B20H56228
6	System board	MB C E50-80 NOK UMA 5200 G DOC	No	No	5B20H56219
6	System board	MB C E50-80 W8P UMA 5200 G DOC	No	No	5B20H56207
6	System board	MB C E50-80 W8S UMA 5200 G DOC	No	No	5B20H56205
6	System board	MB C E50-80 NOK UMA 5200 G NDOC	No	No	5B20H56199
6	System board	MB C E50-80 W8P UMA 5200 G NDOC	No	No	5B20H56190
6	System board	MB C E50-80 W8S UMA 5200 G NDOC	No	No	5B20H56183
6	System board	MB C E50-80 NOK 2G 5010 G DOC	No	No	5B20H56194
6	System board	MB C E50-80 W8P 2G 5010 G DOC	No	No	5B20H56209
6	System board	MB C E50-80 W8S 2G 5010 G DOC	No	No	5B20H56200
6	System board	MB C E50-80 NOK 2G 5010 G NDOC	No	No	5B20H56191
6	System board	MB C E50-80 W8P 2G 5010 G NDOC	No	No	5B20H56185
6	System board	MB C E50-80 W8S 2G 5010 G NDOC	No	No	5B20H56178
6	System board	MB C E50-80 NOK 1G 5010 G DOC	No	No	5B20H56262
6	System board	MB C E50-80 W8P 1G 5010 G DOC	No	No	5B20H56253
6	System board	MB C E50-80 W8S 1G 5010 G DOC	No	No	5B20H56245
6	System board	MB C E50-80 NOK 1G 5010 G NDOC	No	No	5B20H56237
6	System board	MB C E50-80 W8P 1G 5010 G NDOC	No	No	5B20H56227
6	System board	MB C E50-80 W8S 1G 5010 G NDOC	No	No	5B20H56217

Table 3. Major FRUs (continued)

No.	FRU parts	FRU descriptions	Self-service CRU	Optional-service CRU	FRU No.
6	System board	MB C E50-80 NOK UMA 5010 G DOC	No	No	5B20H56208
6	System board	MB C E50-80 W8P UMA 5010 G DOC	No	No	5B20H56250
6	System board	MB C E50-80 W8S UMA 5010 G DOC	No	No	5B20H56241
6	System board	MB C E50-80 NOK UMA 5010 G NDOC	No	No	5B20H56231
6	System board	MB C E50-80 W8P UMA 5010 G NDOC	No	No	5B20H56226
6	System board	MB C E50-80 W8S UMA 5010 G NDOC	No	No	5B20H56216
6	System board	MB C E50-80 NOK 2G 5005 G DOC	No	No	5B20H56204
6	System board	MB C E50-80 W8P 2G 5005 G DOC	No	No	5B20H56230
6	System board	MB C E50-80 W8S 2G 5005 G DOC	No	No	5B20H56220
6	System board	MB C E50-80 NOK 2G 5005 G NDOC	No	No	5B20H56210
6	System board	MB C E50-80 W8P 2G 5005 G NDOC	No	No	5B20H56201
6	System board	MB C E50-80 W8S 2G 5005 G NDOC	No	No	5B20H56193
6	System board	MB C E50-80 NOK 1G 5005 G DOC	No	No	5B20H56187
6	System board	MB C E50-80 W8P 1G 5005 G DOC	No	No	5B20H56180
6	System board	MB C E50-80 W8S 1G 5005 G DOC	No	No	5B20H56264
6	System board	MB C E50-80 NOK 1G 5005 G NDOC	No	No	5B20H56256
6	System board	MB C E50-80 W8P 1G 5005 G NDOC	No	No	5B20H56258
6	System board	MB C E50-80 W8S 1G 5005 G NDOC	No	No	5B20H56249
6	System board	MB C E50-80 NOK UMA 5005 G DOC	No	No	5B20H56240
6	System board	MB C E50-80 W8P UMA 5005 G DOC	No	No	5B20H56242
6	System board	MB C E50-80 W8S UMA 5005 G DOC	No	No	5B20H56233
6	System board	MB C E50-80 NOK UMA 5005 G NDOC	No	No	5B20H56224
6	System board	MB C E50-80 W8P UMA 5005 G NDOC	No	No	5B20H56215
6	System board	MB C E50-80 W8S UMA 5005 G NDOC	No	No	5B20H56247
6	System board	MB C E50-80 NOK 2G 3805 G DOC	No	No	5B20H56236
6	System board	MB C E50-80 W8P 2G 3805 G DOC	No	No	5B20H56225
6	System board	MB C E50-80 W8S 2G 3805 G DOC	No	No	5B20H56213
6	System board	MB C E50-80 NOK 2G 3805 G NDOC	No	No	5B20H56214
6	System board	MB C E50-80 W8P 2G 3805 G NDOC	No	No	5B20H56203
6	System board	MB C E50-80 W8S 2G 3805 G NDOC	No	No	5B20H56196
6	System board	MB C E50-80 NOK 1G 3805 G DOC	No	No	5B20H56186
6	System board	MB C E50-80 W8P 1G 3805 G DOC	No	No	5B20H56179
6	System board	MB C E50-80 W8S 1G 3805 G DOC	No	No	5B20H56263

Table 3. Major FRUs (continued)

No.	FRU parts	FRU descriptions	Self-service CRU	Optional-service CRU	FRU No.
6	System board	MB C E50-80 NOK 1G 3805 G NDOC	No	No	5B20H56255
6	System board	MB C E50-80 W8P 1G 3805 G NDOC	No	No	5B20H56195
6	System board	MB C E50-80 W8S 1G 3805 G NDOC	No	No	5B20H56192
6	System board	MB C E50-80 NOK UMA 3805 G DOC	No	No	5B20H56182
6	System board	MB C E50-80 W8P UMA 3805 G DOC	No	No	5B20H56176
6	System board	MB C E50-80 W8S UMA 3805 G DOC	No	No	5B20H56259
6	System board	MB C E50-80 NOK UMA 3805 G NDOC	No	No	5B20H56254
6	System board	MB C E50-80 W8P UMA 3805 G NDOC	No	No	5B20H56246
6	System board	MB C E50-80 W8S UMA 3805 G NDOC	No	No	5B20H56238
7	Battery	Battery: 4 cell 2.2Ah SY L13S4A01 14.4V32Wh	Yes	No	121500242
7	Battery	Battery: 4 cell 2.2Ah SP/L L13M4A01 14.4V32Wh	Yes	No	121500243
7	Battery	Battery: 4 cell 2.2Ah LG L13L4A01 14.4V32Wh	Yes	No	121500244
8	Wlan	Intel WP1 3160 1x1ac+BT M.2 ROW Combo.(BT ROM update)	Yes	No	SW10A11511
8	Wlan	Intel StP 7265 2x2ac+BT M.2 Combo Non-Vpro Sku.	Yes	No	SW10A11518
8	Wlan	Cbt BCM43162 1x1AC+BT4.0 PCIE M.2 WLAN V2	Yes	No	SW10A11586
8	Wlan	Ltn NFA345 1x1AC+BT4.0 PCIE M.2 WLAN V2	Yes	No	SW10A11628
8	Wlan	Cbt BCM43142 1x1BN+BT4.0 PCIE M.2 WLAN	Yes	No	20200557
8	Wlan	Ltn NFA335 1x1BN+BT4.0 PCIE M.2 WLAN	Yes	No	20200558
8	Wlan	Cbt RTL8723BE 1x1BN+BT4.0 PCIE M.2 WLAN	Yes	No	20200570
8	Wlan	Cbt BCM4352 2x2AC+BT4.0 PCIE M.2 WLAN	Yes	No	20200480
8	Wlan	Ltn NFA344 2x2AC+BT4.0 PCIE M.2 WLAN V2	Yes	No	SW10A11630
9	CPU Fan	CPU Fan C E50-70	No	No	5F10H44792
10	Thermal Module	Heat-Sink C E50-70 DIS	No	No	5H40H44761
10	Thermal Module	Heat-Sink C E50-70 UMA	No	No	5H40H44909
11	IO board	IO Board C E50-70	No	No	5C50H44903
12	Speaker	Speaker C E50-70 W/Cushion	No	No	5SB0H44821



Table 3. Major FRUs (continued)

No.	FRU parts	FRU descriptions	Self-service CRU	Optional-service CRU	FRU No.
13	LED board (only for E40)	LED Board: E40-30	No	No	5C50G07300
14	Lower Cover	Lower CoverCE50-70W/DC IN hole	No	No	5CB0H44833
14	Lower Cover	Lower Cover C E50-70 W/Docking	No	No	5CB0H44830
15	HDD	Hard Disk Drive: 320G 5400rpm ST320LT012 6G 7mm 5.4K 320G HDD	Yes	No	16200384
15	HDD	Hard Disk Drive: 320G 5400rpm TSB MQ01ABF032 6G 7mm 5.4K 320G HDD	Yes	No	16200434
15	HDD	Hard Disk Drive: 320G 5400rpm WD3200LPCX-24C6HT0 6G 7mm 5.4K 320G HDD	Yes	No	16200551
15	HDD	Hard Disk Drive: 500G 5400rpm ST500LT012 6G 7mm 5.4K 500G HDD	Yes	No	16200383
15	HDD	Hard Disk Drive: 500G 5400rpm WD5000LPCX-24C6HT0 6G 7mm 5.4K 500G HDD	Yes	No	16200395
15	HDD	Hard Disk Drive: 1TB 5400rpm ST1000LM024 6G 9.5mm 5.4K 1T HDD	Yes	No	16200385
15	HDD	Hard Disk Drive: 1TB 5400rpm WD10JPCX-24UE4T0 6G 9.5mm 5.4K 1T HDD	Yes	No	16200393
15	HDD	Hard Disk Drive: 1TB 5400rpm TSB MQ01ABD100 6G 9.5mm 5.4K 1T HDD	Yes	No	16200429
15	SSHD	Solid State Hybrid Drive: Seagate KahunaR ST500LM000 7mm 5.4K 500G+8G	Yes	No	5H20H24608
15	SSHD	Solid State Hybrid Drive: 500G +8 G Hybrid ST500LM000 6G 7mm 500G+8G SSHD	Yes	No	16200391
15	SSHD	Solid State Hybrid Drive: 1T +8G Hybrid ST1000LM014 9.5mm 1T+8G 5400rpm SSHD	Yes	No	16200389
15	SSHD	Solid State Hybrid Drive: Seagate KahunaR ST1000LM014 9.5mm 1T+8G	Yes	No	5H20H24607
15	HDD	Hard Disk Drive: 7mm 500G HGST Jaguar B7 HTS545050A7E660	Yes	No	5H20H14223
15	SSD	SSD: Samsung MZYTE256HMHP 2.5" 5mm SSD	Yes	No	5SD0G58918
15	SSD	SSD: Samsung MZ7LN256HCHP 2.5" 5mm 256GB SSD	Yes	No	5SD0H00097
15	SSD	SSD: Lite on LDH-256V2S 2.5" 5mm	Yes	No	5SD0H20014
16	Thermal Cover	Thermal Cover C E50-70	Yes	No	5CB0H44865

Table 3. Major FRUs (continued)

No.	FRU parts	FRU descriptions	Self-service CRU	Optional-service CRU	FRU No.
17	ODD	Optical Disk Drive: 9.0 Rambo QSI UJ8FBS 9.0 Rambo ODD	Yes	No	25215312
17	ODD	Optical Disk Drive: 9HLDS GUC0N 9.0mm Slim Tray Rambo ODD	Yes	No	5DX0F85915
17	ODD	Optical Disk Drive: 9PLDS DA-8A6SH 9.0mm Slim Tray Rambo ODD	Yes	No	5DX0F86404
18	ODD Bezel	ODD Bezel C E50-70	Yes	No	5B30H44824
19	FP board	Finger Printer board: ZIWB2 Fingerprint Board Worldfair	No	No	90007268
20	ODD switch board	ODD Switch Board C E50-70	No	No	5C50H44762
21	Battery Board	Battery Board C E50-70	No	No	5C50H44813
22	Docking board	DockingBoardCE50-70W/BK/LED Mat	No	No	5C50H44785

## LCD FRUs

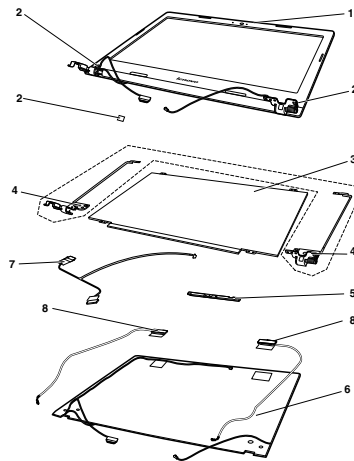

Table 4. LCD FRUs

No.	FRU parts	FRU descriptions	Self-service CRU	Optional-service CRU	PN number
1	LCD bezel	LCD BezelCE50-70W/CAM/MAG/Mylar	No	No	5B30H44763
1	LCD bezel	LCDBezelCE50-70NCAM W/MAG/Mylar	No	No	5B30H44768
2	Screw Mylar	Screw Mylar C E50-70 LCD Bezel	No	No	5T10H44764
3	Panel	Panel: LP156WHB-TPD1	No	No	5D10F76011
3	Panel;	Panel: AUO B156XTN04.1 4A HD AG F LED1 NB LCD	No	No	5D10H20140
3	Panel	Panel: SDC LTN156AT37-402 HD AG F NB	No	No	5D10G93203
3	Panel	Panel: BOE N156WHM-N22 HD AG F NB	No	No	5D10G74898

Table 4. LCD FRUs (continued)

No.	FRU parts	FRU descriptions	Self-service CRU	Optional-service CRU	PN number
3	Panel	Panel: CMI N156BGE-EA1 C2 HD AG S LED1 NB LCD	No	No	18201589
3	Panel	Panel: AUO B156HTN03.8 FHD AG S NB	No	No	5D10H15380
3	Panel	Panel: CMI N156HGE-EAB FHD AG S LED1 NB LCD	No	No	18201584
3	Panel	Panel: BOE HB156FH1-401 FHD AG S LED1 NB LCD	No	No	18201585
4	Hinge	Hinge L+R C E50-70	No	No	5H50H44919
5	Camera	Camera 0.3M C E50-70	No	No	5C20H44797
5	Camera	ZIWB2 Camera Board 1M NT	No	No	90007266
6	LCD Cover	LCD Cover C E50-70	No	No	5CB0H44867
7	EDP Cable	EDP Cable C E50-70 W/CAM Cable	No	No	5C10H44889
7	EDP Cable	EDP Cable C E50-70 WO/CAM Cable	No	No	5C10H44891
8	Antenna	Antenna MAIN+AUX C E50-70	No	No	5A30H44898

## Miscellaneous parts and other FRUs

Table 5. Miscellaneous part

FRU descriptions	Self-service CRU	Optional-service CRU	PN number
(a). HDD Bracket C E50-70	No	No	5B40H44869
(b). ODD bracket: ODD C E50-70	No	No	5B40H44790
(c). Touch Pad board: TP Board C E40-30	No	No	5C10G07301
(d). Audio board cable: IO Board C E50-70	No	No	5C10H44874
(e). DC-in cable: DC-IN Board C E40-30 UMA (only for E40)	No	No	5C10G07314
(e). DC-in cable: DC-IN Board C E40-30 DIS (only for E40)	No	No	5C10G07344
(e). DC-in cable and DC-in board: DC-INBoardCE50-70W/BK/LEDRubber	No	No	5C50H44829
(f). Finger Printer bracket: FP Bracket C E50-70	No	No	5B40H44801
(g). FP Board Cable C E50-70	No	No	5C10H44769
(h). DC-IN Cable C E50-70 DIS	No	No	5C10H44815
(h). DC-IN Cable C E50-70 UMA	No	No	5C10H44787
(i). Docking Cable C E50-70 DIS	No	No	5C10H44781
(i). Docking Cable C E50-70 UMA	No	No	5C10H44772
(i). DockingDC-INCable CE50-70 W/LED	No	No	5C10H44780
Screw Pack C E50-70	No	No	5S10H44754

Table 6. Other FRUs

FRU descriptions	Self-service CRU	Optional-service CRU	PN number
ac adapter 45W 3pin: Delta ADLX45NDC3A 20V2.25A adapter Delta	Yes	No	36200602
ac adapter 45W 3pin: Liteon ADLX45NLC3A 20V2.25A adapter Liteon	Yes	No	36200606
ac adapter 45W 3pin: Chicony ADLX45NCC3A 20V2.25A adapter Chicony	Yes	No	36200610
ac adapter 65W 3pin: Delta ADLX65NDC3A 20V3.25A adapter	Yes	No	36200249
ac adapter 65W 3pin: Liteon ADLX65NLC3A 20V3.25A adapter Liteon	Yes	No	36200607
ac adapter 65W 3pin: Chicony ADLX65NCC3A 20V3.25A adapter Chicony	Yes	No	36200611
Power code UK 3pin: LINETEK LP-61L+ H03VV-F+ LS15 1m code	Yes	No	145000593
Power code UK 3pin: Longwell LP-61L+H03VV-F+LS-18 1m code	Yes	No	145000561
Power code UK 3pin: VOLEX MP5004+H03VV-F+VAC5S 1m code	Yes	No	145000605
Power code UK 3pin: lux 0031+H03VV-F 0.75/3C+0011 1m code	Yes	No	145500000
Power code Europe 3pin: LINETEK LP-34+H03VV-F + LS15 1m code	Yes	No	145000585
Power code Europe 3pin: Longwell LP-34A+H03VV-F+LS-18 1m code	Yes	No	145000553
Power code Europe 3pin: VOLEX M2511+H03VV-F+VAC5S 1m code	Yes	No	145000525
Power code Europe 3pin: lux 0033+H03VV-F 0.75/3C+0011 1m code	Yes	No	145500001
Power code US 3pin: LINETEK LP-30B + SPT-2 + LS15 1m code	Yes	No	145000594
Power code US 3pin: Longwell LP-30B+SPT-2 18AWG+LS-18 1m code	Yes	No	145000562
Power code US 3pin: Volex US15S3+SPT-2 + VAC5S 1m code	Yes	No	145000537
Power code US 3pin: lux 0014+SPT-2 60°C 18/3C+0016 1m code	Yes	No	145500002
Power code China 3pin: LINETEK PC323+RVV300/300+LS15 1m code	Yes	No	145000600
Power code China 3pin: Longwell LSG-31+RVV300/300+LS-18 1m code	Yes	No	145000568
Power code China 3pin: VOLEX GB10S3+RVV 300/500+VAC5S 1m code	Yes	No	145000538
Power code China 3pin: lux 0036+RVV 300/300 0.75/3C+0002 1m code	Yes	No	145500003
Power code India 3pin: LINETEK PE-361+ H05VV-F+ LS15 1m code	Yes	No	145000592
Power code India 3pin: Longwell LP-67+BIS+LS-18 1m code	Yes	No	145000560
Power code India 3pin: lux 0046+IS694 0.75/3C+0011 1m code	Yes	No	145500004

Table 6. Other FRUs (continued)

FRU descriptions	Self-service CRU	Optional-service CRU	PN number
Power code Japan 3pin: LINETEK LS15+VCTF+LP-54 1m code	Yes	No	145000587
Power code Japan 3pin: Longwell LP-54+VCTF+LS-18 1m code	Yes	No	145000555
Power code Japan 3pin: VOLEX VAC5S+VCTF+M755 1m code	Yes	No	145000530
Power code Japan 3pin: lux 0018(E)+VCTF 0.75/3C+0021 1m code	Yes	No	145500005
Power code Australia 3pin: LINETEK LS15+H03VV-F+LP-23A 1m code	Yes	No	145000589
Power code Australia 3pin: Longwell LP-23A+LFC-3R+LS-18 1m code	Yes	No	145000557
Power code Australia 3pin: VOLEX AU10S3+H03VV-F+VAC5S 1m code	Yes	No	145000532
Power code Australia 3pin: lux 0038+H03VV-F 0.75/3C+0011 1m code	Yes	No	145500006
Power code Taiwan 3pin: LINETEK LS15+VCTF+LP-53 1m code	Yes	No	145000588
Power code Taiwan 3pin: Longwell LP-71+VCTF+LS-33 1m code	Yes	No	145000556
Power code Taiwan 3pin: VOLEX TW15CS3+VCTF+VAC5S 1m code	Yes	No	145000531
Power code Taiwan 3pin: lux 0019+VCTF 0.75/3C+0021 1m code	Yes	No	145500007
Power code Korea 3pin: LINETEK LS15+H05VV-F+LP-E04A 1m code	Yes	No	145000590
Power code Korea 3pin: Longwell LP-486+KTLH03VV-F+LS-5 1m code	Yes	No	145000558
Power code Korea 3pin: VOLEX M2511+KETI IEC+VAC5S 1m code	Yes	No	145000533
Power code Korea 3pin: lux 0033+H03VV-F 0.75/3C+0011 1m code	Yes	No	145500008
Power code Italy 3pin: LINETEK LS15+H03VV-F+PE-336 1m code	Yes	No	145000591
Power code Italy 3pin: Longwell LP-22+H03VV-F+LS-18 1m code	Yes	No	145000559
Power code Italy 3pin: VOLEX IT10S3+H03VV-F+VAC5S 1m code	Yes	No	145000535
Power code Italy 3pin: lux 0029+H03VV-F 0.75/3C+0011 1m code	Yes	No	145500009
Power code South Africa 3pin: LINETEK LS15+H03VV-F+PE-364 1m code	Yes	No	145000586
Power code South Africa 3pin: Longwell LP-39+H03VV-F+LS-18 1m code	Yes	No	145000554
Power code South Africa 3pin: lux 0044+H03VV-F 0.75/3C+0011 1m code	Yes	No	145500010
Power code Brazil 3pin: LINETEK LS15 H03VV-F LP26A 1m code	Yes	No	145000596
Power code Brazil 3pin: Longwell LP-46+H03VV-F+LS-18 1m code	Yes	No	145000564

Table 6. Other FRUs (continued)

FRU descriptions	Self-service CRU	Optional-service CRU	PN number
Power code Brazil 3pin: VOLEX CH10S3+H03VV-F+VAC5S 1m code	Yes	No	145000527
Power code Brazil 3pin: lux 0034+H03VV-F 0.75/3C+0011 1m code	Yes	No	145500011
Power code Israel 3pin: LINETEK LS15+H03VV-F+LP-41 1m code	Yes	No	145000595
Power code Israel 3pin: Longwell LP-41+H03VV-F+LS-18 1m code	Yes	No	145000563
Power code Israel 3pin: VOLEX SI16S3+H03VV-F+VAC5S 1m code	Yes	No	145000526
Power code Israel 3pin: lux 0041+H03VV-F 0.75/3C+0011 1m code	Yes	No	145500012
Power code Switzerland 3pin: LINETEK LS15+H03VV-F+LP-37 1m code	Yes	No	145000597
Power code Switzerland 3pin: Longwell LP-37+H03VV-F+LS-18 1m code	Yes	No	145000565
Power code Switzerland 3pin: VOLEX MP232+H03VV-F+VAC5S 1m code	Yes	No	145000524
Power code Switzerland 3pin: lux 0027+H03VV-F 0.75/3C+0011 1m code	Yes	No	145500013
Power code Denmark 3pin: LINETEK LS15+H03VV-F+LP-38 1m code	Yes	No	145000598
Power code Denmark 3pin: Longwell LP-40+H03VV-F+LS-18 1m code	Yes	No	145000566
Power code Denmark 3pin: VOLEX MP233D+H03VV-F+VAC5S 1m code	Yes	No	145000534
Power code Denmark 3pin: lux 0048+H03VV-F 0.75/3C+0011 1m code	Yes	No	145500014
Power code Argentina 3pin: LINETEK LS15+H03VV-F+LP39 1m code	Yes	No	145000599
Power code Argentina 3pin: Longwell LP-24+H03VV-F+LS-18 1m code	Yes	No	145000567
Power code Argentina 3pin: VOLEX VA2073+H03VV-F+VAC5S 1m code	Yes	No	145000528
Power code Argentina 3pin: lux 0040+H03VV-F 0.75/3C+0011 1m code	Yes	No	145500015
Keyboard Sunrex: US102KeyT6G1DFBikKBikFrameKBD	No	Yes	25214785
Keyboard Sunrex: UK103KeyT6G1DFBikKBikFrameKBD	No	Yes	25214786
Keyboard Sunrex: Italian103KeyT6G1DFBikKBikFrameKBD	No	Yes	25214787
Keyboard Sunrex: Spanish103KeyT6G1DFBikKBikFrameKBD	No	Yes	25214788
Keyboard Sunrex: Turkish103KeyT6G1DFBikKBikFrameKBD	No	Yes	25214789
Keyboard Sunrex: Thailand102KeyT6G1DFBikKBikFrameKBD	No	Yes	25214790
Keyboard Sunrex: Portugue103KeyT6G1DFBikKBikFrameKBD	No	Yes	25214791

Table 6. Other FRUs (continued)

FRU descriptions	Self-service CRU	Optional-service CRU	PN number
Keyboard Sunrex: LatinSpa103KeyT6G1DFBIkKBikFrameKBD	No	Yes	25214792
Keyboard Sunrex: CanadFrEn103KeyT6G1DFBIkKBikFrameKBD	No	Yes	25214793
Keyboard Sunrex: Korean102KeyT6G1DFBIkKBikFrameKBD	No	Yes	25214794
Keyboard Sunrex: TradChine102KeyT6G1DFBIkKBikFrameKBD	No	Yes	25214795
Keyboard Sunrex: Russian102KeyT6G1DFBIkKBikFrameKBD	No	Yes	25214796
Keyboard Sunrex: French103KeyT6G1DFBIkKBikFrameKBD	No	Yes	25214797
Keyboard Sunrex: German103KeyT6G1DFBIkKBikFrameKBD	No	Yes	25214798
Keyboard Sunrex: Arabic102KeyT6G1DFBIkKBikFrameKBD	No	Yes	25214799
Keyboard Sunrex: Brazilian103KeyT6G1DFBIkKBikFrameKBD	No	Yes	25214800
Keyboard Sunrex: Dutch103KeyT6G1DFBIkKBikFrameKBD	No	Yes	25214802
Keyboard Sunrex: Greek102KeyT6G1DFBIkKBikFrameKBD	No	Yes	25214803
Keyboard Sunrex: Hebrew102KeyT6G1DFBIkKBikFrameKBD	No	Yes	25214804
Keyboard Sunrex: Hungarian103KeyT6G1DFBIkKBikFrameKBD	No	Yes	25214805
Keyboard Sunrex: Nordic103KeyT6G1DFBIkKBikFrameKBD	No	Yes	25214806
Keyboard Sunrex: Belgian103KeyT6G1DFBIkKBikFrameKBD	No	Yes	25214807
Keyboard Sunrex: Iceland103KeyT6G1DFBIkKBikFrameKBD	No	Yes	25214808
Keyboard Sunrex: Slovenian103KeyT6G1DFBIkKBikFrameKBD	No	Yes	25214809
Keyboard Sunrex: Swiss103KeyT6G1DFBIkKBikFrameKBD	No	Yes	25214810
Keyboard Sunrex: USInter102KeyT6G1DFBIkKBikFrameKBD	No	Yes	25214811
Keyboard Sunrex: Czh-Slk103KeyT6G1DFBIkKBikFrameKBD	No	Yes	25214812
Keyboard Sunrex: Bulgarian103KeyT6G1DFBIkKBikFrameKBD	No	Yes	25214813
Keyboard Sunrex: India102KeyT6G1DFBIkKBikFrameKBD	No	Yes	25214814
Keyboard: US102KeyT6G1JMEBIkKBikFrameKBD	No	Yes	25214755
Keyboard: UK103KeyT6G1JMEBIkKBikFrameKBD	No	Yes	25214756
Keyboard: Italian103KeyT6G1JMEBIkKBikFrameKBD	No	Yes	25214757
Keyboard: Spanish103KeyT6G1JMEBIkKBikFrameKBD	No	Yes	25214758
Keyboard: Turkish103KeyT6G1JMEBIkKBikFrameKBD	No	Yes	25214759
Keyboard: Thailand102KeyT6G1JMEBIkKBikFrameKBD	No	Yes	25214760
Keyboard: Portugue103KeyT6G1JMEBIkKBikFrameKBD	No	Yes	25214761
Keyboard: LatinSpa103KeyT6G1JMEBIkKBikFrameKBD	No	Yes	25214762
Keyboard: CanadFrEn103KeyT6G1JMEBIkKBikFrameKBD	No	Yes	25214763
Keyboard: Korean102KeyT6G1JMEBIkKBikFrameKBD	No	Yes	25214764
Keyboard: TradChine102KeyT6G1JMEBIkKBikFrameKBD	No	Yes	25214765
Keyboard: Russian102KeyT6G1JMEBIkKBikFrameKBD	No	Yes	25214766
Keyboard: French103KeyT6G1JMEBIkKBikFrameKBD	No	Yes	25214767
Keyboard: German103KeyT6G1JMEBIkKBikFrameKBD	No	Yes	25214768
Keyboard: Arabic102KeyT6G1JMEBIkKBikFrameKBD	No	Yes	25214769

Table 6. Other FRUs (continued)

FRU descriptions	Self-service CRU	Optional-service CRU	PN number
Keyboard: Brazilian103KeyT6G1JMEBikKBikFrameKBD	No	Yes	25214770
Keyboard: Dutch103KeyT6G1JMEBikKBikFrameKBD	No	Yes	25214772
Keyboard: Greek102KeyT6G1JMEBikKBikFrameKBD	No	Yes	25214773
Keyboard: Hebrew102KeyT6G1JMEBikKBikFrameKBD	No	Yes	25214774
Keyboard: Hungarian103KeyT6G1JMEBikKBikFrameKBD	No	Yes	25214775
Keyboard: Nordic103KeyT6G1JMEBikKBikFrameKBD	No	Yes	25214776
Keyboard: Belgian103KeyT6G1JMEBikKBikFrameKBD	No	Yes	25214777
Keyboard: Iceland103KeyT6G1JMEBikKBikFrameKBD	No	Yes	25214778
Keyboard: Slovenian103KeyT6G1JMEBikKBikFrameKBD	No	Yes	25214779
Keyboard: Swiss103KeyT6G1JMEBikKBikFrameKBD	No	Yes	25214780
Keyboard: USInter102KeyT6G1JMEBikKBikFrameKBD	No	Yes	25214781
Keyboard: Czh-Slk103KeyT6G1JMEBikKBikFrameKBD	No	Yes	25214782
Keyboard: Bulgarian103KeyT6G1JMEBikKBikFrameKBD	No	Yes	25214783
Keyboard: India102KeyT6G1JMEBikKBikFrameKBD	No	Yes	25214784
Keyboard: US102KeyT6G1CCYBikKBikFrameKBD	No	Yes	25214725
Keyboard: UK103KeyT6G1CCYBikKBikFrameKBD	No	Yes	25214726
Keyboard: Italian103KeyT6G1CCYBikKBikFrameKBD	No	Yes	25214727
Keyboard: Spanish103KeyT6G1CCYBikKBikFrameKBD	No	Yes	25214728
Keyboard: Turkish103KeyT6G1CCYBikKBikFrameKBD	No	Yes	25214729
Keyboard: Thailand102KeyT6G1CCYBikKBikFrameKBD	No	Yes	25214730
Keyboard: Portugue103KeyT6G1CCYBikKBikFrameKBD	No	Yes	25214731
Keyboard: LatinSpa103KeyT6G1CCYBikKBikFrameKBD	No	Yes	25214732
Keyboard: CanadFrEn103KeyT6G1CCYBikKBikFrameKBD	No	Yes	25214733
Keyboard: Korean102KeyT6G1CCYBikKBikFrameKBD	No	Yes	25214734
Keyboard: TradChine102KeyT6G1CCYBikKBikFrameKBD	No	Yes	25214735
Keyboard: Russian102KeyT6G1CCYBikKBikFrameKBD	No	Yes	25214736
Keyboard: French103KeyT6G1CCYBikKBikFrameKBD	No	Yes	25214737
Keyboard: German103KeyT6G1CCYBikKBikFrameKBD	No	Yes	25214738
Keyboard: Arabic102KeyT6G1CCYBikKBikFrameKBD	No	Yes	25214739
Keyboard: Brazilian103KeyT6G1CCYBikKBikFrameKBD	No	Yes	25214740
Keyboard: Dutch103KeyT6G1CCYBikKBikFrameKBD	No	Yes	25214742
Keyboard: Greek102KeyT6G1CCYBikKBikFrameKBD	No	Yes	25214743
Keyboard: Hebrew102KeyT6G1CCYBikKBikFrameKBD	No	Yes	25214744
Keyboard: Hungarian103KeyT6G1CCYBikKBikFrameKBD	No	Yes	25214745
Keyboard: Nordic103KeyT6G1CCYBikKBikFrameKBD	No	Yes	25214746
Keyboard: Belgian103KeyT6G1CCYBikKBikFrameKBD	No	Yes	25214747
Keyboard: Iceland103KeyT6G1CCYBikKBikFrameKBD	No	Yes	25214748



Table 6. Other FRUs (continued)

<b>FRU descriptions</b>	<b>Self-service CRU</b>	<b>Optional-service CRU</b>	<b>PN number</b>
Keyboard: Slovenian103KeyT6G1CCYBIkKBikFrameKBD	No	Yes	25214749
Keyboard: Swiss103KeyT6G1CCYBIkKBikFrameKBD	No	Yes	25214750
Keyboard: USInter102KeyT6G1CCYBIkKBikFrameKBD	No	Yes	25214751
Keyboard: Czh-Slk103KeyT6G1CCYBIkKBikFrameKBD	No	Yes	25214752
Keyboard: Bulgarian103KeyT6G1CCYBIkKBikFrameKBD	No	Yes	25214753
Keyboard: India102KeyT6G1CCYBIkKBikFrameKBD	No	Yes	25214754



---

## Chapter 9. FRU replacement notices

This chapter presents notices related to removing and replacing parts. Read this chapter carefully before replacing any FRU.

### CRU statement for customers:

You can resolve some problems with your product with a replacement part you can install yourself, called a “Customer Replaceable Unit” or “CRU.” Some CRUs are designated as self-service CRUs and others are designated as optional-service CRUs. *Installation of self-service CRUs is your responsibility. For optional-service CRUs, you can either install the CRU yourself or you can request that a Service Provider install the CRU according to the warranty service for your product.* If you intend on installing the CRU, Lenovo will ship the CRU to you. CRU information and replacement instructions are shipped with your product and are available from Lenovo at any time upon request. You can find a list of CRUs for your product in this *Hardware Maintenance Manual*. An electronic version of this manual can be found at <http://www.lenovo.com/UserManuals>. Follow the on-screen instructions to find the manual for your product. You might be required to return the defective part that is replaced by the CRU. When return is required: (1) return instructions, a prepaid shipping label, and a container will be included with the replacement CRU; and (2) you might be charged for the replacement CRU if Lenovo does not receive the defective CRU within thirty (30) days of your receipt of the replacement CRU. See your Lenovo Limited Warranty documentation for full details.

---

## Screw notices

Loose screws can cause a reliability problem. In the ThinkPad notebook computer, this problem is addressed with special nylon-coated screws that have the following characteristics:

- They maintain tight connections.
- They do not easily come loose, even with shock or vibration.
- They are harder to tighten.

Do the following when you service this machine:

- Keep the screw kit in your tool bag. crew kit.
- Remove screws carefully for reuse.
- Use a torque screwdriver if you have one.

Tighten screws as follows:

- **Plastic to plastic**

Turn an additional 90 degrees after the screw head touches the surface of the plastic part.

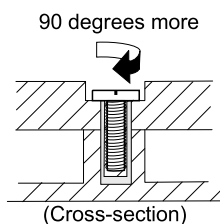

- **Logic card to plastic**

Turn an additional 180 degrees after the screw head touches the surface of the logic card.

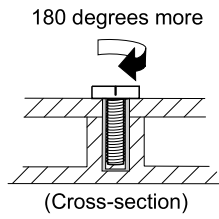

**Notes:**

- Ensure that you use the correct screw. If you have a torque screwdriver, tighten all screws firmly to the torque specified in the screw information table for each step.
- Ensure that torque screwdrivers are calibrated correctly following country specifications.

---

## Chapter 10. Removing or replacing a FRU

This chapter provides instructions on how to remove or replace a FRU.

### CRU statement for customers:

You can resolve some problems with your product with a replacement part you can install yourself, called a “Customer Replaceable Unit” or “CRU.” Some CRUs are designated as self-service CRUs and others are designated as optional-service CRUs. *Installation of self-service CRUs is your responsibility. For optional-service CRUs, you can either install the CRU yourself or you can request that a Service Provider install the CRU according to the warranty service for your product.* If you intend on installing the CRU, Lenovo will ship the CRU to you. CRU information and replacement instructions are shipped with your product and are available from Lenovo at any time upon request. You can find a list of CRUs for your product in this *Hardware Maintenance Manual*. An electronic version of this manual can be found at <http://www.lenovo.com/UserManuals>. Follow the on-screen instructions to find the manual for your product. You might be required to return the defective part that is replaced by the CRU. When return is required: (1) return instructions, a prepaid shipping label, and a container will be included with the replacement CRU; and (2) you might be charged for the replacement CRU if Lenovo does not receive the defective CRU within thirty (30) days of your receipt of the replacement CRU. See your Lenovo Limited Warranty documentation for full details.

**Note:** The illustrations used in this section are of the Lenovo E40, unless otherwise stated.

---

### General guidelines

When removing or replacing a FRU, be sure to observe the following general guidelines:

1. Do not try to service any computer unless you have been trained and certified. An untrained person runs the risk of damaging parts.
2. Before replacing any FRU, review Chapter 9 “FRU replacement notices” on page 49.
3. Begin by removing any FRUs that have to be removed before replacing the failing FRU. Any such FRUs are listed at the beginning of each FRU replacement section. Remove them in the order in which they are listed.
4. Follow the correct sequence in the steps for removing a FRU, as given in the illustrations by the numbers in square callouts.
5. When turning a screw, turn it in the direction as given by the arrow in the illustration.
6. When removing a FRU, move it in the direction as given by the arrow in the illustration.
7. To put the new FRU in place, reverse the removal procedure and follow any notes that pertain to replacement.
8. When replacing a FRU, use the correct screws as shown in the replacement procedures.



**Before removing any FRU, turn off the computer, unplug all power cords from electrical outlets, and then disconnect any interconnecting cables.**

**Attention:** After replacing a FRU, do not turn on the computer until you have made sure that all screws, springs, and other small parts are in place and none are loose inside the computer. Verify this by shaking the computer gently and listening for rattling sounds. Metallic parts or metal flakes can cause electrical short circuits.

**Attention:** The system board is sensitive to, and can be damaged by, electrostatic discharge (ESD). Before touching it, establish personal grounding by touching a ground point with one hand or by using an electrostatic discharge strap.

---

## 1010 External battery pack

### Important notices for replacing a battery pack

**Attention:** Lenovo has no responsibility for the performance or safety of unauthorized batteries, and provides no warranties for failures or damage arising out of their use.

The Lenovo Solution Center program provides an automatic battery diagnostic test that determines if the battery pack is defective. A battery pack FRU should not be replaced unless this diagnostic test shows that the battery is defective. The only exception to this is if the battery pack is physically damaged or a customer is reporting a possible safety issue.

If the Lenovo Solution Center program is not installed on the computer, the customer should download and install the program to diagnose the battery pack, before getting a non-physically damaged battery pack replaced. Note that the replacement of a physically damaged battery pack is not covered by the warranty.

### Removal steps of the external battery pack



**Use only the authorized battery specified for your computer. Any other battery could ignite or explode.**

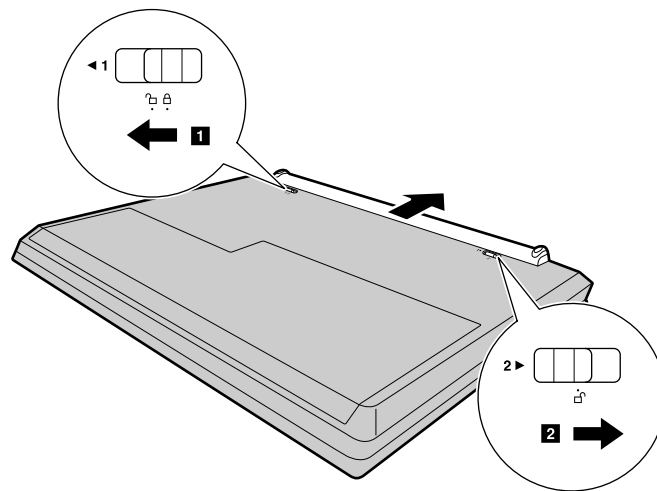

---

## 1020 Keyboard

For access, remove these FRUs:

- “1010 External battery pack” on page 52

## Removal steps of the keyboard

Remove two screws **1** (E40).

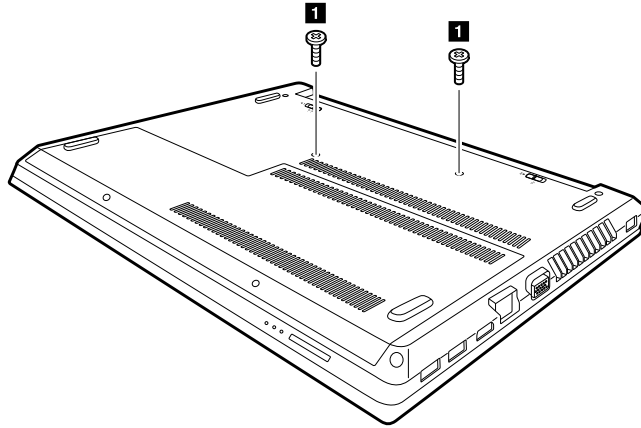

Remove three screws **1** (E50).

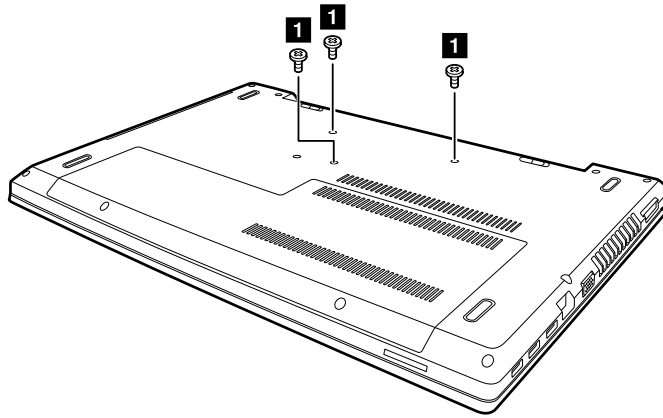

Step	Screw (quantity)	Color	Torque
<b>1</b>	M2.0 × 6mm, flat-head, nylok-coated	Black	1.85 +/- 0.15kgf-cm

Lift the keyboard a little by its upper edge with a flat blade **2**, and then slide the keyboard frame forward in the direction shown by arrow **3**.

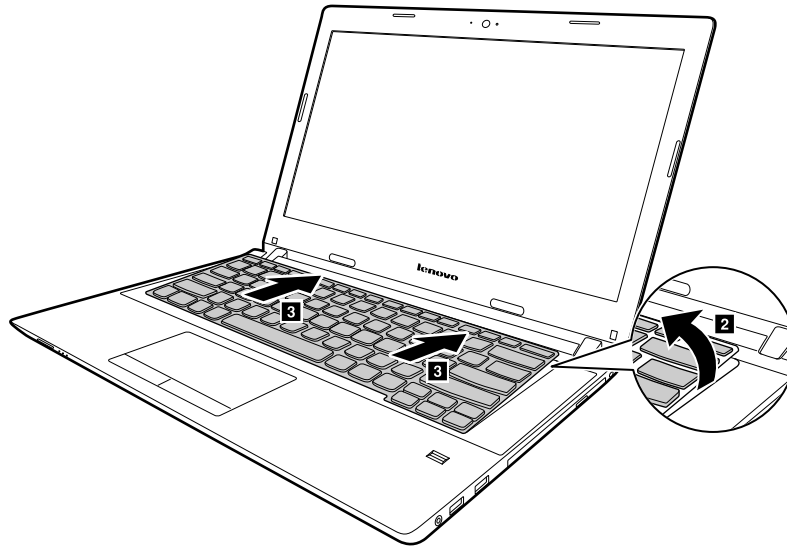

Lift the keyboard a little **4**, and then detach the connector in the direction shown by arrows **5** **6**.

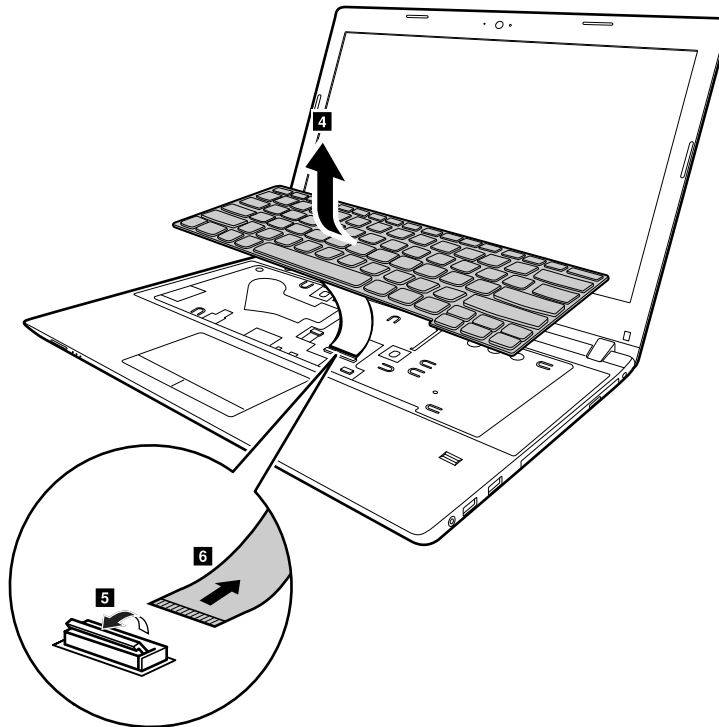

#### When installing

Make sure that the connector is firmly attached.

---

### 1030 Optical disk drive

For access, remove these FRUs in order:

- “1010 External battery pack” on page 52



## Removal steps of the Optical drive

Remove the screw **1** (E40).

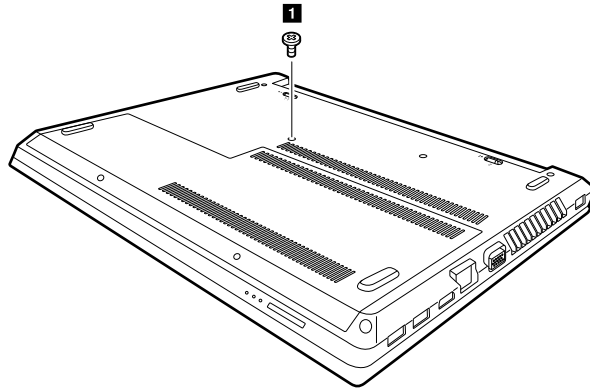

Remove the screw **1** (E50).

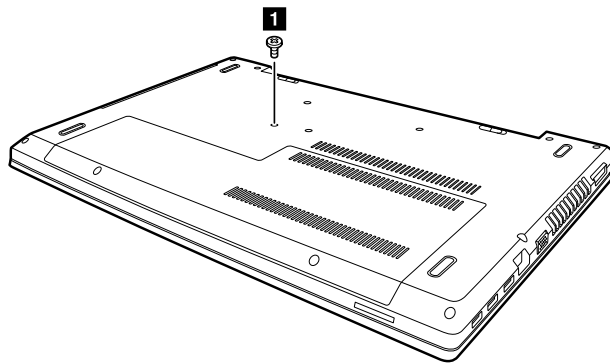

Step	Screw (quantity)	Color	Torque
<b>1</b>	SCREW M2*6mm, flat-head, nylok-coated	Black	1.85 +/- 0.15kgf-cm

Insert a screwdriver into the screw hold and push the optical driver in the direction shown by arrow **2**. Pull the optical drive out in the direction shown by arrow **3**.

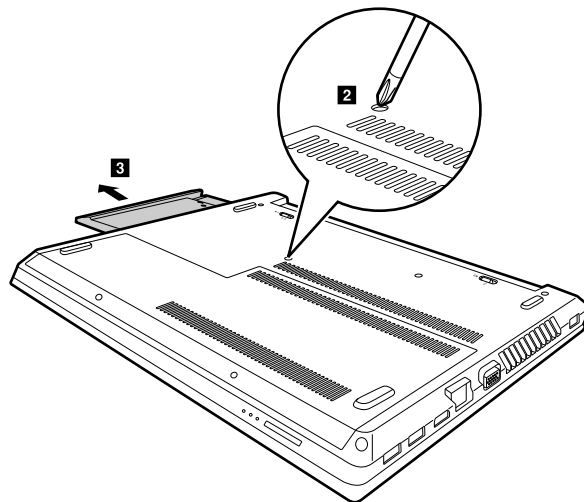

Remove the ODD bezel **4**. Loosen two screws **5** and then detach the ODD bracket **6**.

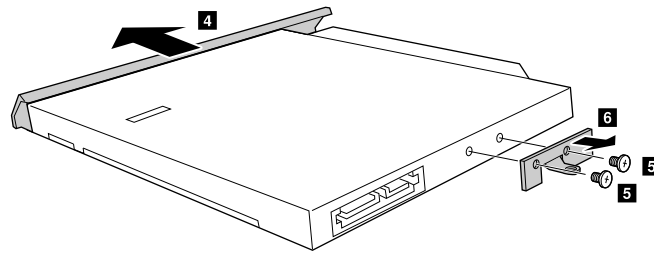

Step	Screw (quantity)	Color	Torque
<b>5</b>	SCREW M2*3mm, flat-head, nylok-coated (2)	Black	1.85 +/- 0.15kgf-cm

## 1040 Base cover assembly

For access, remove these FRUs:

- “1010 External battery pack” on page 52

### Removal steps of the base cover assembly

Remove the screws **1** that secure the base cover assembly. Remove the base cover assembly **2**.

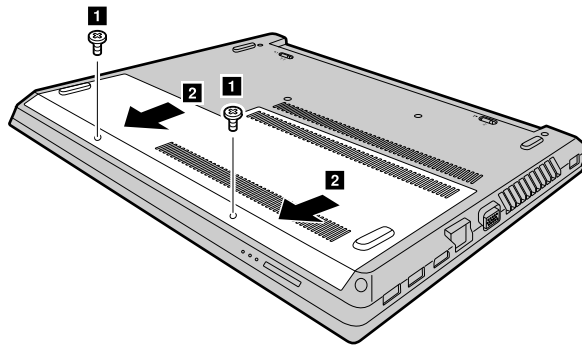

Step	Screw (quantity)	Color	Torque
<b>1</b>	SCREW M2.5*6mm, flat-head, nylok-coated (2)	Black	3.0 +/- 0.3kgf-cm

### Applying labels to the base cover assembly:

The new base cover assembly is shipped with a kit containing labels of several kinds. Apply those labels when you replace the base cover assembly. For the labels that are not shipped with the new base cover assembly, peel them from the old base cover assembly, and adhere them to the new one.

**Note:** If the Certificate of Authenticity (COA) label (b) is attached to a replaced part, return the replaced part to the customer, or provide a letter to the customer stating the original label part number, serial number, and product key.

The following illustration shows the location of each label on E40.

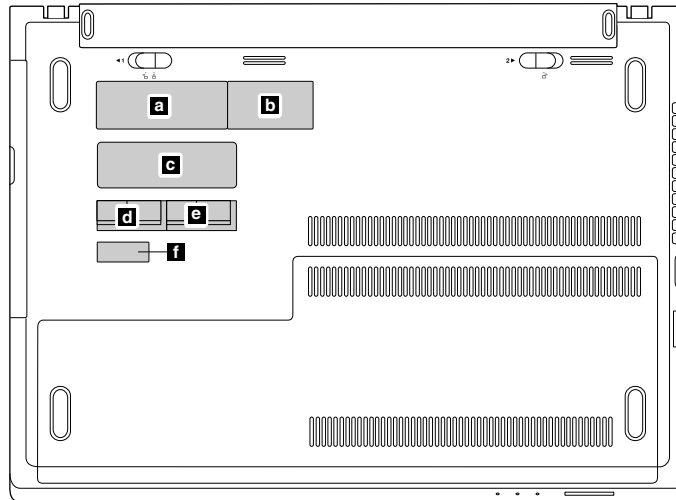

- |  |                                 |
|--|---------------------------------|
| <b>a</b> Rating label  | <b>d</b> Wlan label             |
| <b>b</b> Rating print label                                  | <b>e</b> BT label               |
| <b>c</b> COA label (windows 7) / GML label (for windows 8.1) | <b>f</b> Indonesia rating label |

The following illustration shows the location of each label on E50.

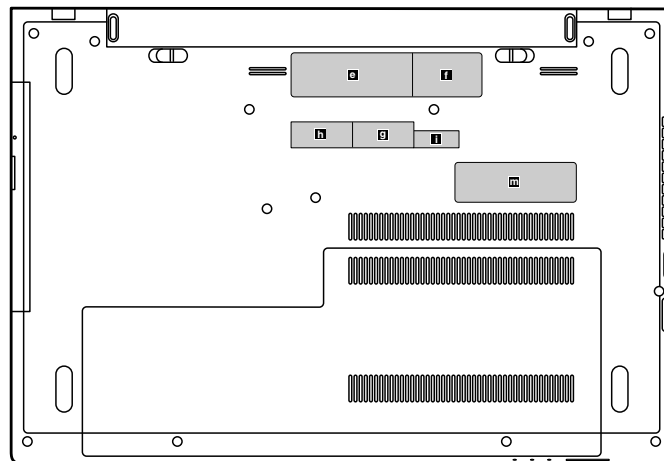

- |                             |  |
|-----------------------------|--|
| <b>e</b> Rating label       | <b>g</b> BIS label for India                             |
| <b>f</b> Rating print label | <b>i</b> Indonesia rating label                          |
| <b>h</b> Wlan/BT label      | <b>m</b> COA label (windows 7) / GML label (windows 8.1) |

## 1050 Hard disk drive or solid-state hybrid drive

For access, remove these FRUs in order:

- “1010 External battery pack” on page 52
- “1040 Base cover assembly” on page 56

### Attention:

- Do not drop the drive or apply any physical shock to it. The drive is sensitive to physical shock. Improper handling can cause damage and permanent loss of data.
- Before removing the drive, have the user make a backup copy of all the information on it if possible.
- Never remove the drive while the system is operating or in suspend mode.

### Removal steps of the hard disk drive or the solid-state drive

Remove the screws **1**.

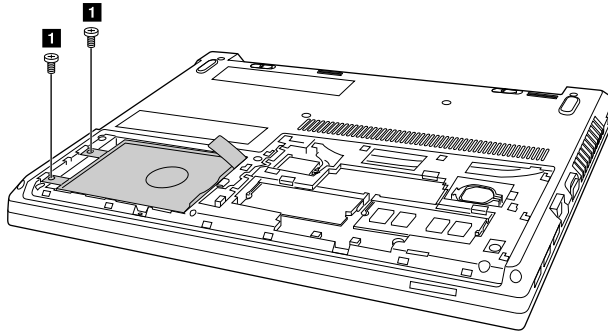

Step	Screw (quantity)	Color	Torque
<b>1</b>	M2.5 × 6mm, flat-head, nylon-coated (2) (E40)	Black	3.0 +/- 0.3kgf-cm
	M2.5 × 4mm, flat-head, nylon-coated (2) (E50)	White	3.0 +/- 0.3kgf-cm

Slide the hard disk drive in the direction shown by arrow **2**.

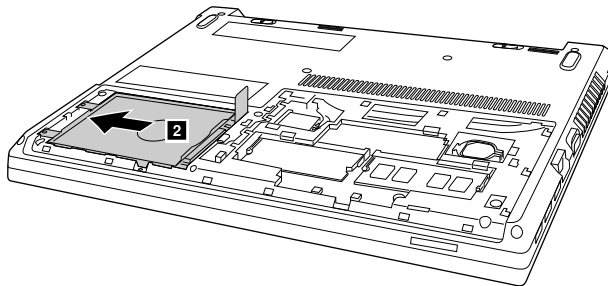

Pull the hard disk drive out **3** .

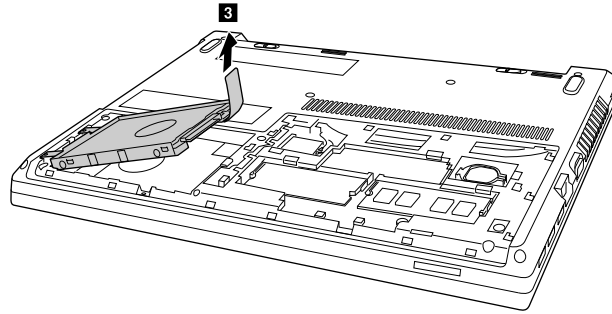

Detach the bracket by removing the four screws **4**.

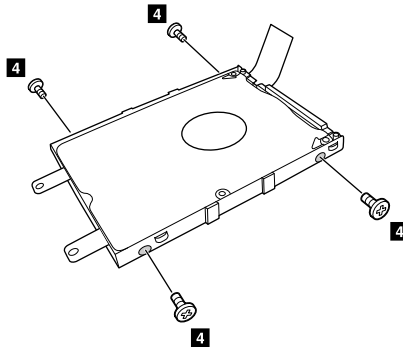

Step	Screw (quantity)	Color	Torque
<b>4</b>	M3 × 3mm, flat-head, nylon-coated (4)	Black	3.0 +/- 0.3kgf-cm

**When installing:**

Ensure that the hard disk drive or solid-state hybrid drive is firmly attached.

---

## 1060 Wireless-LAN /Bluetooth card

For access, remove these FRUs in order:

- “1010 External battery pack” on page 52
- “1040 Base cover assembly” on page 56

## Removal steps of the Wireless-LAN /Bluetooth card

Unplug the two wireless Lan cable (black and white) in the direction shown by arrow **1**, and then remove the screw **2**

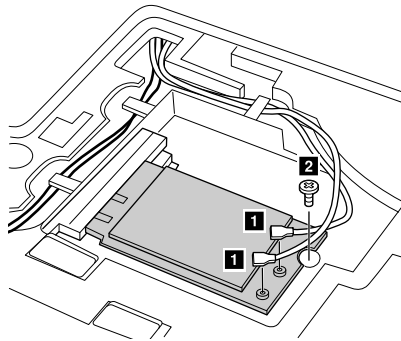

Step	Screw (quantity)	Color	Torque
<b>2</b>	M2 × 3 mm, flat-head, nylon-coated (1)	Black	1.85 +/- 0.15kgf-cm

Remove the card in the direction shown by arrow **3**.

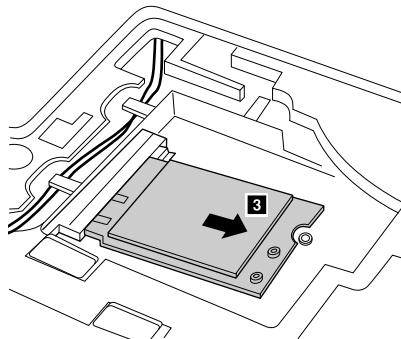

### When installing:

1. In models with a wireless LAN card that has two antenna connectors, plug the black cable (1st) (MAIN) into the jack labeled **MAIN** or **1** on the card, and the white cable (2nd) (AUX) into jack labeled **AUX** or **2** on the card.
2. In models with a wireless LAN card that has three antenna connectors, plug the black cable (1st) (MAIN) into the jack labeled **MAIN** or **1**, the grey cable (3rd) into jack labeled **1**, and the white cable (2nd) (AUX) into jack labeled **2** on the card.

---

## 1070 Memory module

For access, remove these FRUs in order:

- “1010 External battery pack” on page 52
- “1040 Base cover assembly” on page 56

## Removal steps of the memory module

Release the two latches on both edges of the socket at the same time in the direction shown by arrows **1**, and then unplug the DIMM in the direction shown by arrow **2**.

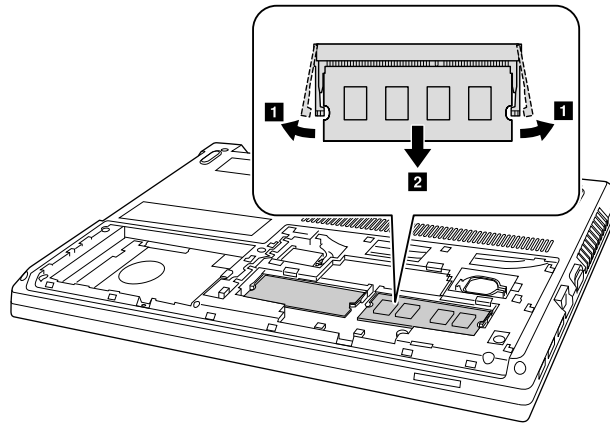

### When installing:

Insert the notched end of the memory module into the memory slot. Press the memory module in firmly, and pivot it downward until it snaps into place. Ensure that the memory module is firmly installed in the slot and does not move easily.

---

## 1080 Upper case

For access, remove these FRUs in order:

- “1010 External battery pack” on page 52
- “1020 Keyboard” on page 52
- “1030 Optical disk drive” on page 54
- “1040 Base cover assembly” on page 56
- “1050 Hard disk drive or solid-state hybrid drive” on page 58
- “1060 Wireless-LAN /Bluetooth card” on page 59

## Removal steps of the upper case

Remove eight screws **1** and two screws **2** on the bottom. (E40)

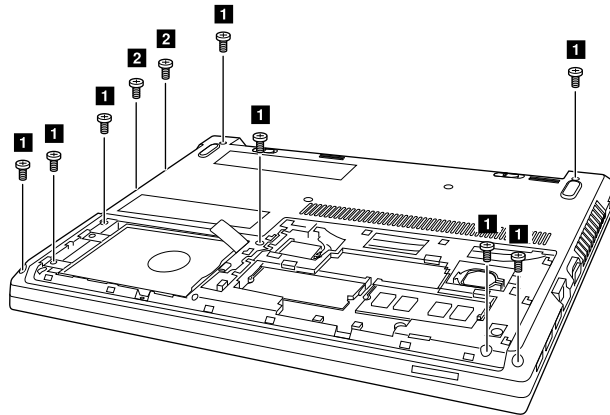

Remove nine screws **1** and three screws **2** on the bottom. (E50)

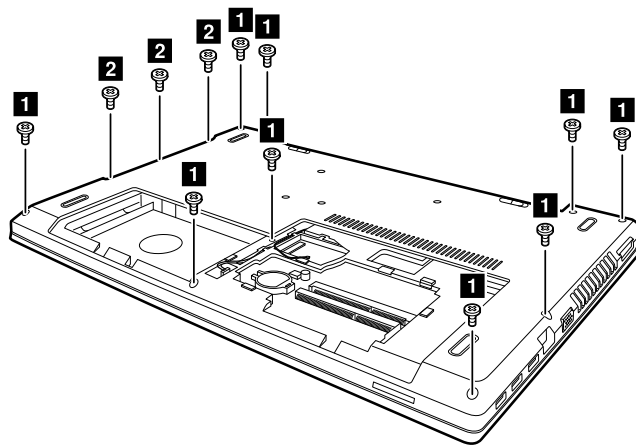

Step	Screw (quantity)	Color	Torque
<b>1</b>	M2.5 × 6mm, flat-headed, nylon-coated (8) (E40)	Black	3.0 +/- 0.3kgf-cm
	M2.5 × 7mm, flat-headed, nylon-coated (9) (E50)	Black	3.0 +/- 0.3kgf-cm
<b>2</b>	M2.0 × 2mm, flat-headed, nylon-coated	Black	1.85 +/- 0.15kgf-cm



Detach power board connector, LED board connector, touch pad connector and finger print reader connector in the direction shown by arrows **3** **4**.

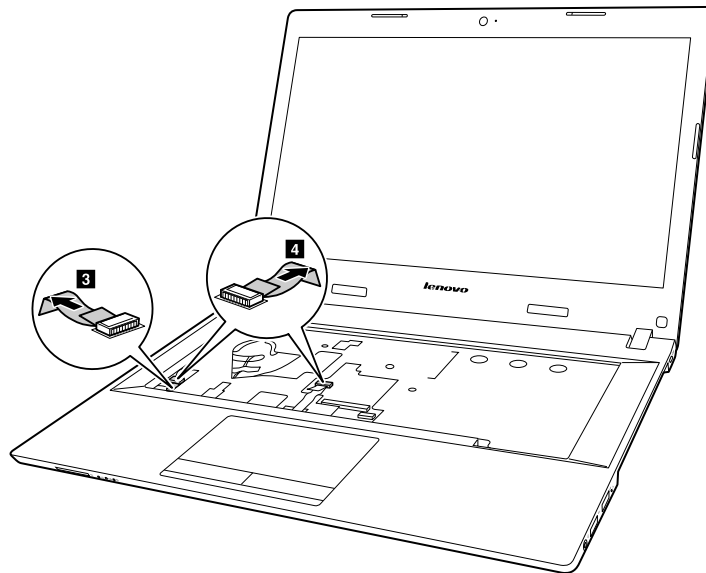

**When installing:** Ensure that all the connectors are attached firmly.

Remove the upper case in the direction shown by arrow **5**.

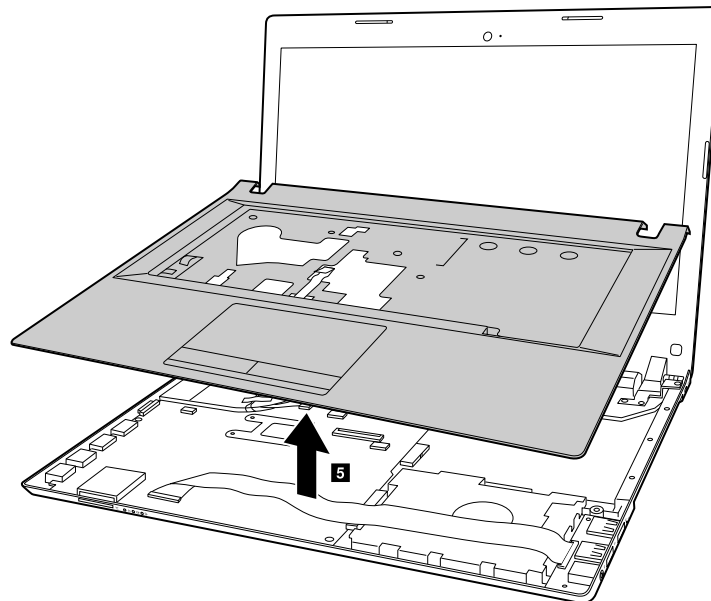

---

## 1090 Audio board, audio board cable, power board, touch pad board cable, finger printer board, LED board and ODD switch board

For access, remove these FRUs in order:

- “1010 External battery pack” on page 52
- “1020 Keyboard” on page 52
- “1030 Optical disk drive” on page 54
- “1040 Base cover assembly” on page 56

- “1050 Hard disk drive or solid-state hybrid drive” on page 58
- “1060 Wireless-LAN /Bluetooth card” on page 59
- “1080 Upper case” on page 61

**Removal steps of audio board, audio board cable, power board, touch pad board cable, finger printer board, LED board and ODD switch board**

Detach Audio board cable connector **1**. Remove one screw **2**, and then remove the audio board in the direction shown by arrow **3**.

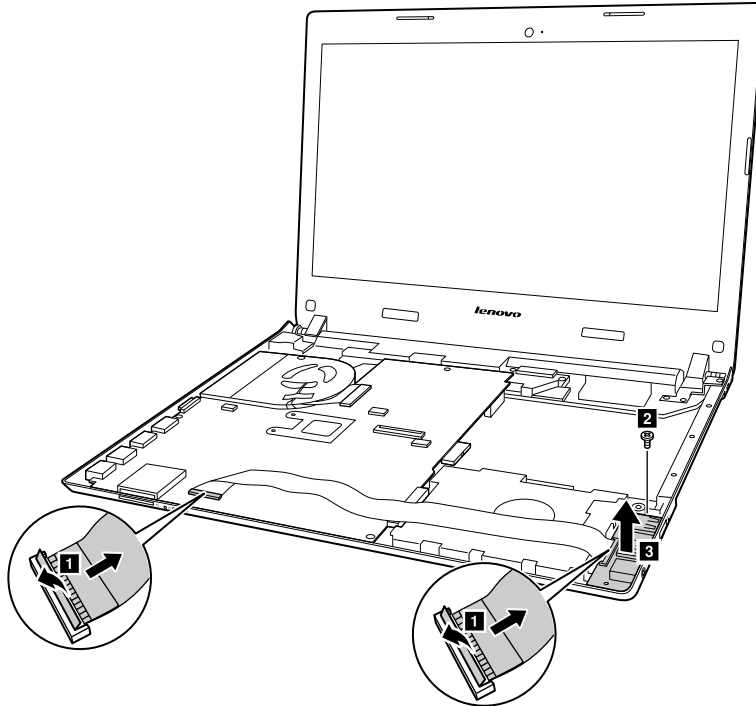

Step	Screw (quantity)	Color	Torque
<b>2</b>	M2.5 × 4 mm, flat-head, nylon-coated (1)	silver	3.0 +/- 0.3kgf-cm

**When installing:** make sure that the audio board cable connector is firmly attached.

Peel off the adhesive tape securing the power board, remove one screw **4**, and then remove the power board in the direction shown by arrow **5**.

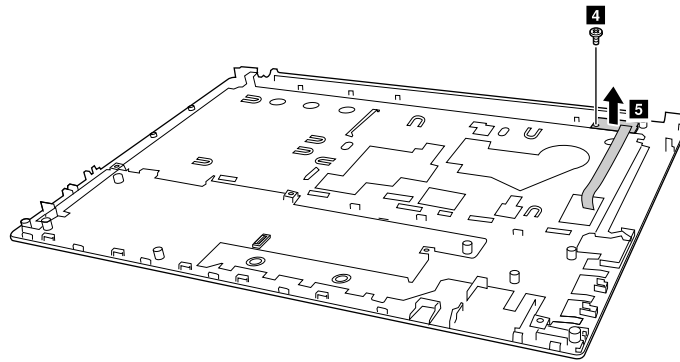

Step	Screw (quantity)	Color	Torque
<b>4</b>	M2 × 3mm, flat-head, nylon-coated (1)	black	1.85 +/- 0.15kgf-cm

Detach the connector **6**, and then remove the touch pad board cable in the direction shown by arrow **7**.

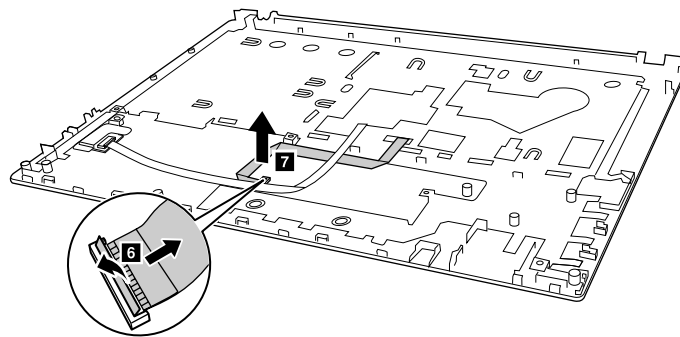

**When installing:** make sure that the touch pad board cable connector is firmly attached.

Remove one screw **8**, and then remove the finger printer bracket in the direction shown by arrow **9**.

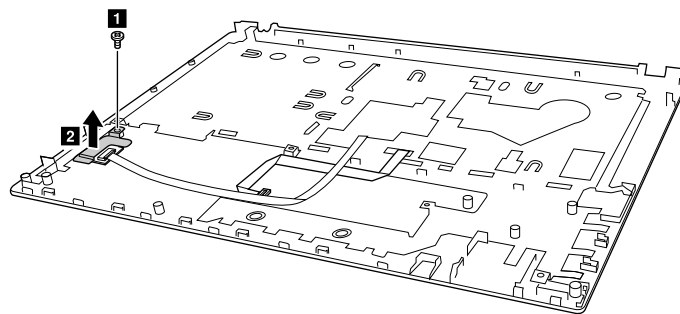

Step	Screw (quantity)	Color	Torque
<b>8</b>	M2 × 3mm, flat-head, nylon-coated (1)	black	1.85 +/- 0.15kgf-cm

Remove the finger printer board in the direction shown by arrow **10**.

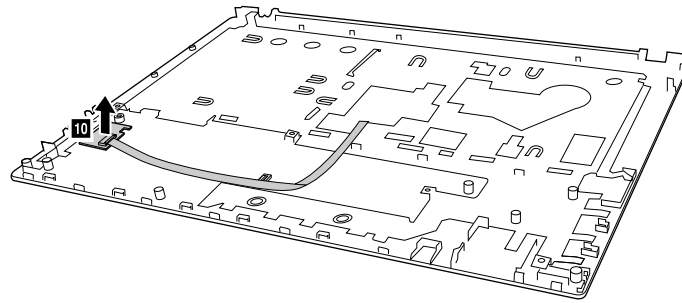

Push forward the LED board **11** and remove it in the direction shown by arrow **12** (E40).

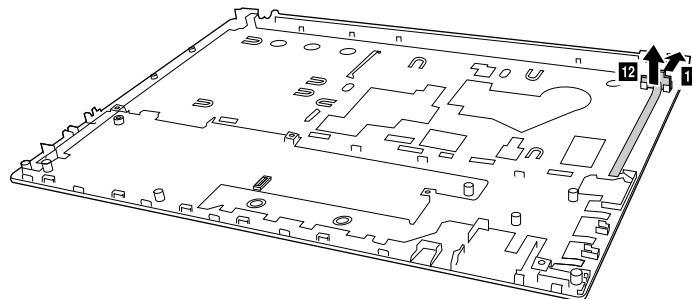

Detach ODD switch board connector **14**, remove two screws **15**, and then remove the ODD switch board in the direction shown by arrow **16** (E50).

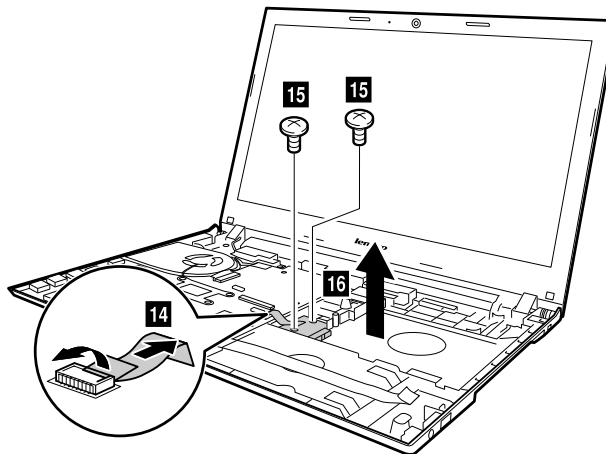

Step	Screw (quantity)	Color	Torque
<b>4</b>	M2.5 × 4mm, flat-head, nylon-coated (2)	silver	3.0 +/- 0.3kgf-cm

## 1100 System board

### Important notices for handling the system board

When handling the system board, read the following:

- Be careful not to drop the system board on a bench top that has a hard surface, such as metal, wood, or composite.

- Avoid rough handling of any kind.
- At every point in the process, be sure not to drop or stack the system board.
- If you put a system board down, be sure to put it only on a padded surface such as an ESD mat or a corrugated conductive material.

For access, remove these FRUs in order:

- “1010 External battery pack” on page 52
- “1020 Keyboard” on page 52
- “1030 Optical disk drive” on page 54
- “1040 Base cover assembly” on page 56
- “1050 Hard disk drive or solid-state hybrid drive” on page 58
- “1060 Wireless-LAN /Bluetooth card” on page 59
- “1080 Upper case” on page 61
- “1090 Audio board, audio board cable, power board, touch pad board cable, finger printer board, LED board and ODD switch board” on page 63

### Removal steps of the system board

Detach EDP cable connector **1**.

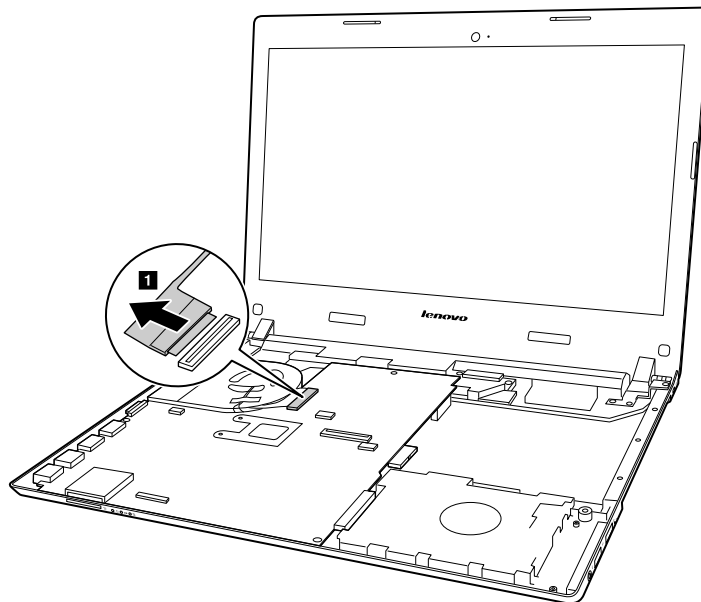

Remove one screw **2** and three screws **3**.

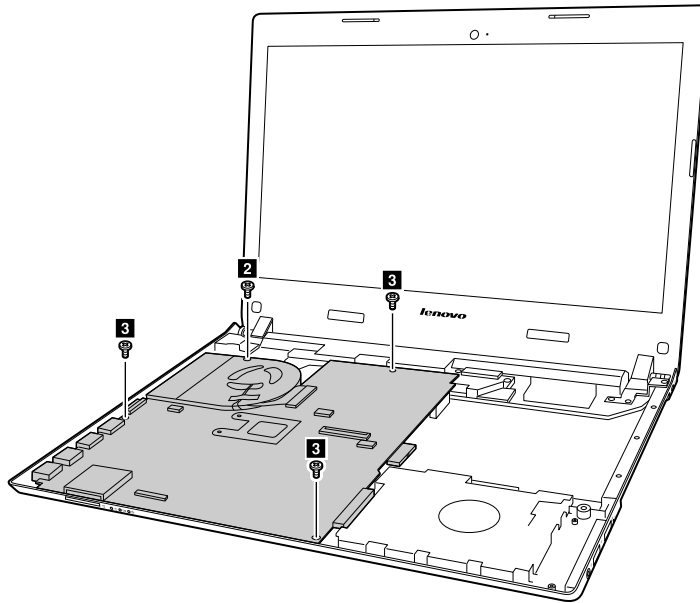

Remove one screw **2** and four screws **3**.

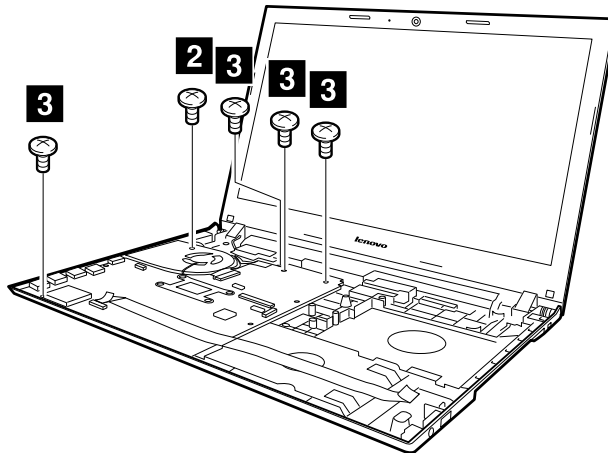

Step	Screw (quantity)	Color	Torque
<b>2</b>	M2 × 5mm, flat-headed, nylon-coated (1) (E40)	Silver	1.85 +/- 0.15kgf-cm
	M2 × 6mm, flat-headed, nylon-coated (1) (E50)	Black	1.85 +/- 0.15kgf-cm
<b>3</b>	M2.5 × 6mm, flat-headed, nylon-coated (3) (E40)	Black	3.0 +/- 0.3kgf-cm
	M2.5 × 4mm, flat-headed, nylon-coated (4) (E50)	Silver	3.0 +/- 0.3kgf-cm

Unplug DC-in cable connector **4**.

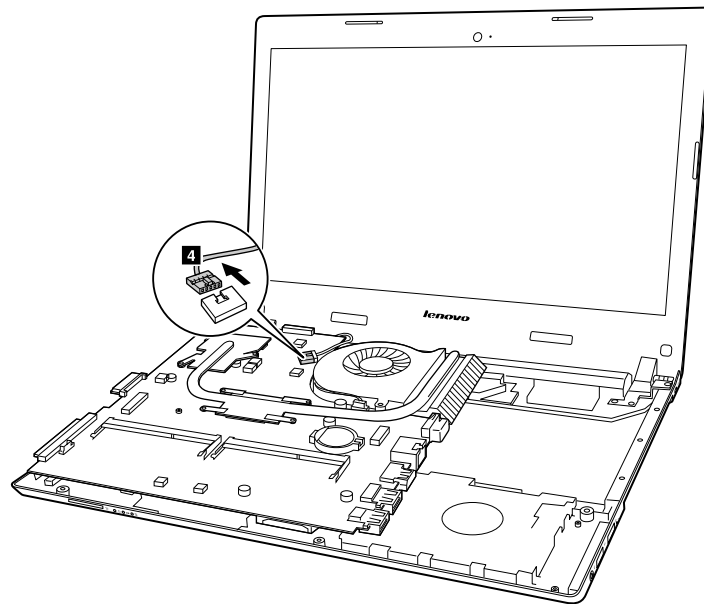

**When installing:** Ensure that the connectors are attached firmly.

Remove the system board in the direction shown by arrow **5**.

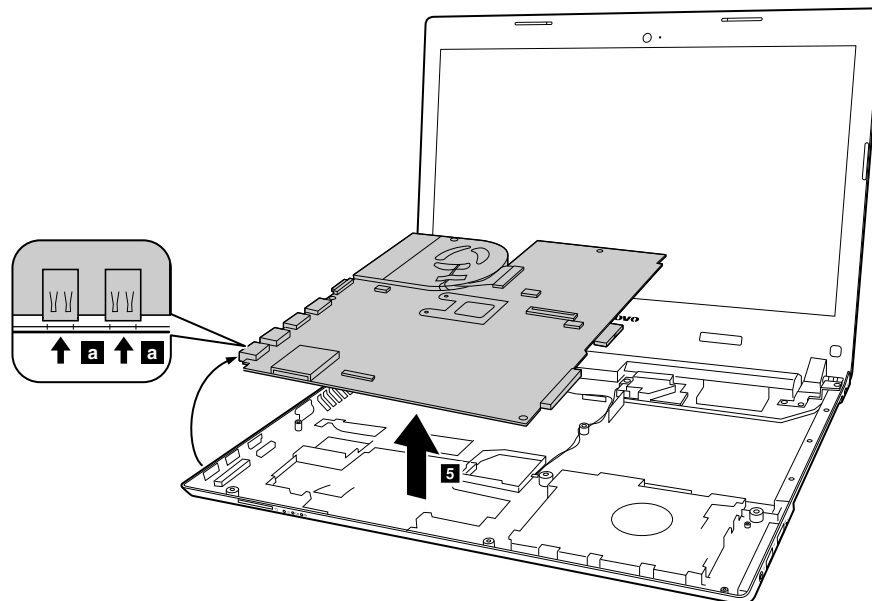

**When installing:** When attaching the system board to the base cover, adjust the placement of the USB ports as shown in **a**, and make sure that they are attached to the holes on the base cover as shown. Improper placement of those jacks might cause a damage.

---

## 1110 Battery Board, Thermal fan assembly and Heat Sink assembly

For access, remove these FRUs in order:

- “1010 External battery pack” on page 52
- “1020 Keyboard” on page 52

- “1030 Optical disk drive” on page 54
- “1040 Base cover assembly” on page 56
- “1050 Hard disk drive or solid-state hybrid drive” on page 58
- “1060 Wireless-LAN /Bluetooth card” on page 59
- “1080 Upper case” on page 61
- “1090 Audio board, audio board cable, power board, touch pad board cable, finger printer board, LED board and ODD switch board” on page 63
- “1100 System board” on page 66

### Removal steps of the battery board

Loosen two screws **1** and then remove the battery board in the direction shown by arrow **2** (E50).

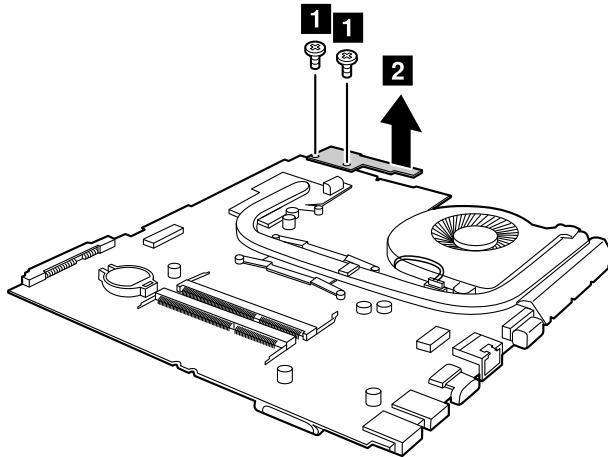

Step	Screw (quantity)	Color	Torque
<b>1</b>	M2.0 × 3mm, flat-headed, nylon-coated (2)	Black	1.85 +/- 0.15kgf-cm

### Removal steps of the thermal fan assembly

Loosen six screws **3** and one screw **4**.

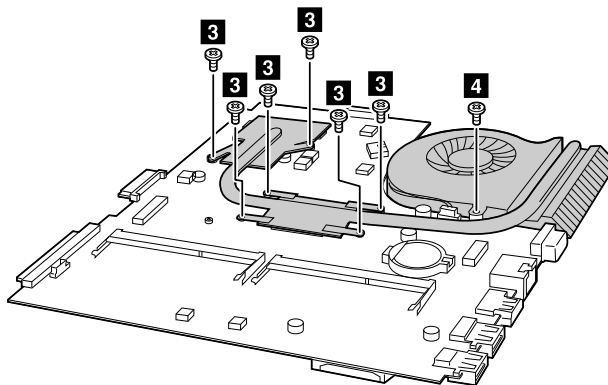

Step	Screw (quantity)	Color	Torque
<b>3</b>	M2.0 × 3mm, flat-headed, nylon-coated (6)	Black	1.85 +/- 0.15kgf-cm
<b>4</b>	M2.0 × 5mm, flat-headed, nylon-coated (1) (E40)	Silver	1.85 +/- 0.15kgf-cm
	M2.0 × 6mm, flat-headed, nylon-coated (1) (E50)	Black	1.85 +/- 0.15kgf-cm

Remove the heat sink assembly in the direction shown by arrow **5**.



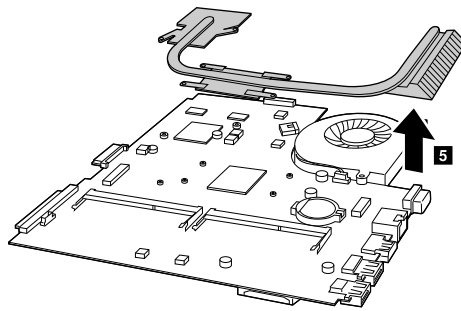

Unplug the fan connector in the direction shown by arrow **5**.

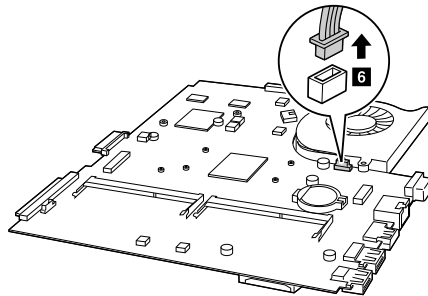

**When installing:** Ensure that the fan connector is attached firmly.

Remove the thermal fan assembly in the direction shown by arrow **7**.

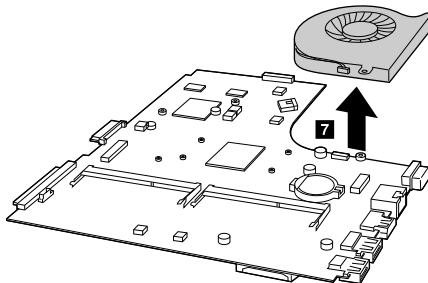

## 1120 Speaker assembly, docking LED lens and docking bracket

For access, remove these FRUs in order:

- “1010 External battery pack” on page 52
- “1020 Keyboard” on page 52
- “1030 Optical disk drive” on page 54
- “1040 Base cover assembly” on page 56
- “1050 Hard disk drive or solid-state hybrid drive” on page 58
- “1060 Wireless-LAN /Bluetooth card” on page 59
- “1080 Upper case” on page 61
- “1090 Audio board, audio board cable, power board, touch pad board cable, finger printer board, LED board and ODD switch board” on page 63
- “1100 System board” on page 66

### Removal steps of the speaker assembly, docking LED lens and docking bracket

Release antenna and LVDS cables from the cable guide, loosen four screws **1** and remove the speakers **2**.

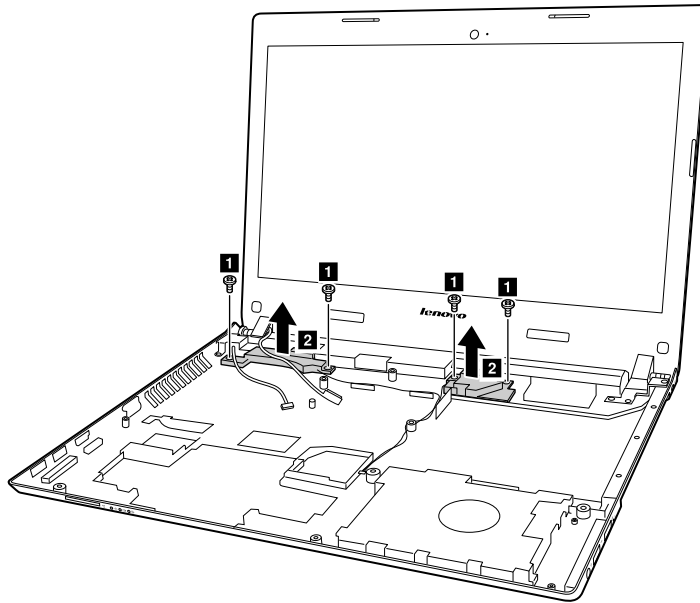

Step	Screw (quantity)	Color	Torque
<b>1</b>	M2 × 3mm, big head, nylon-coated (4) (E40)	Black	1.85 +/- 0.15kgf-cm
	M2 × 3mm, big head, nylon-coated (4) (E50)	Black	1.85 +/- 0.15kgf-cm

**Attention:** As you route the cables, ensure that they are not subject to any tension. Tension could cause the cables to be damaged by the cable guides, or a wire to be broken.

### Removal steps of the docking LED lens and docking bracket(E50)

Carefully pull out the docking LED lens in the direction shown by arrow **3**.

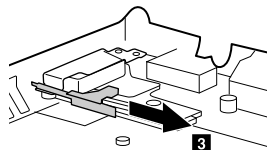

Loose one screw **4** and then remove the docking bracket in the direction shown by arrow **5**.

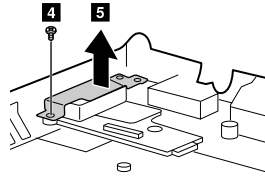

Step	Screw (quantity)	Color	Torque
<b>4</b>	M2.5 × 5mm, flat head, nylon-coated (1)	Black	3.0 +/- 0.3kgf-cm

## 1130 LCD unit, docking board, docking cable and DC-in cable

For access, remove this FRU:

- “1010 External battery pack” on page 52
- “1020 Keyboard” on page 52
- “1030 Optical disk drive” on page 54
- “1040 Base cover assembly” on page 56
- “1050 Hard disk drive or solid-state hybrid drive” on page 58
- “1060 Wireless-LAN /Bluetooth card” on page 59
- “1080 Upper case” on page 61
- “1090 Audio board, audio board cable, power board, touch pad board cable, finger printer board, LED board and ODD switch board” on page 63
- “1100 System board” on page 66
- “1120 Speaker assembly, docking LED lens and docking bracket” on page 72

## Removal steps of the LCD unit, docking board, docking cable and DC-in cable

Release the antenna cables from the cable guide **1**, and then remove two screws **2** and two screws **3**.

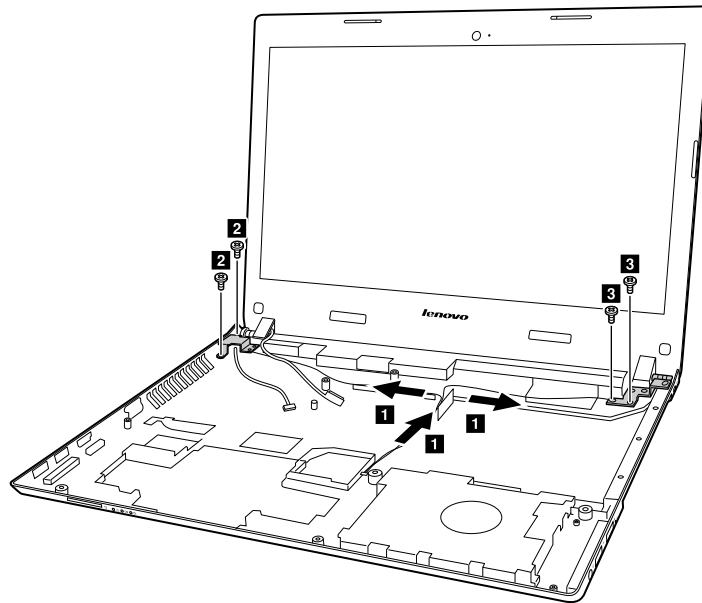

Step	Screw (quantity)	Color	Torque
<b>2</b>	M2.5 × 6mm, flat-headed, nylon-coated (2) (E40)	Black	3.0 +/- 0.3kgf-cm
	M2.5 × 5mm, flat-headed, nylon-coated (2) (E50)	Black	3.0 +/- 0.3kgf-cm
<b>3</b>	M2.5 × 4mm, flat-headed, nylon-coated (2) (E40)	Silver	3.0 +/- 0.3kgf-cm
	M2.5 × 5mm, flat-headed, nylon-coated (2) (E50)	Black	3.0 +/- 0.3kgf-cm

### When installing:

- Route the antenna cables along the cable guides. As you route the cables, make sure that they are not subjected to any tension. Tension could cause the cables to be damaged by the cable guides, or a wire to be broken.
- Make sure that the LCD connector is attached firmly and make sure that you do not pinch the antenna cables when you attach the LCD assembly. Route the LCD cable along the cable guides.

Detach the LCD unit from the upper case **4**.

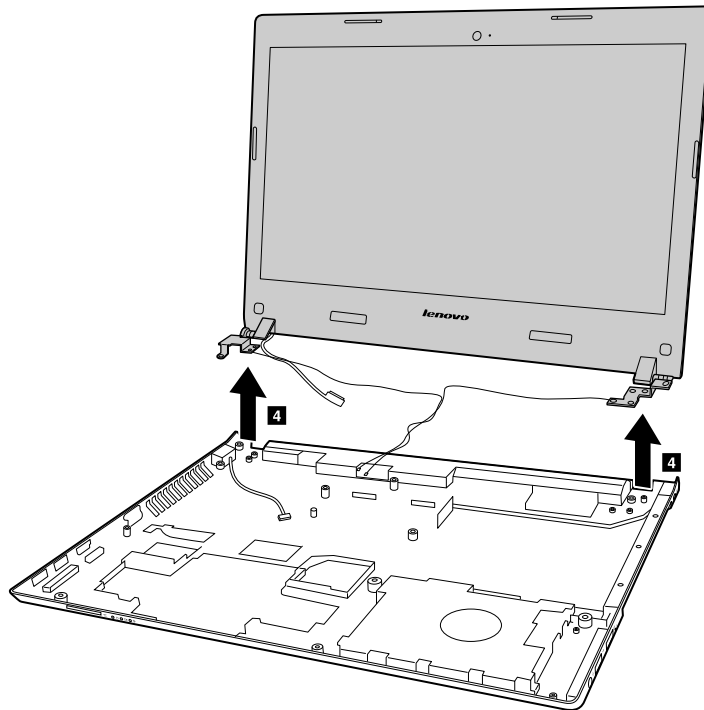

Remove the DC-in cable **5** (E40).

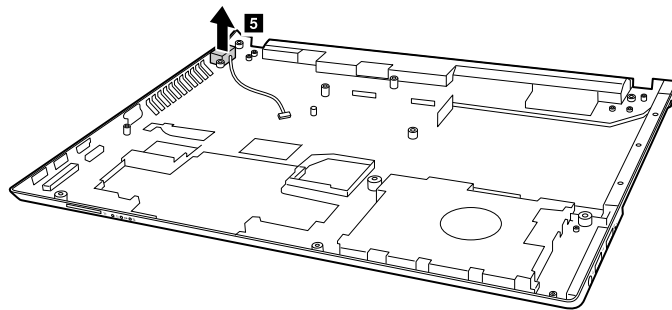

Loose one screw **5** and then remove the docking board, docking cable and DC-in cable in the direction shown by arrow **6** (E50).

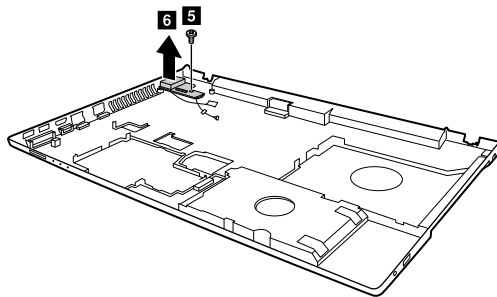

Step	Screw (quantity)	Color	Torque
<b>5</b>	M2.5 × 4mm, flat head, nylon-coated (1)	Silver	3.0 +/- 0.3kgf-cm

---

## 1140 LCD front bezel

For access, remove this FRU:

- “1010 External battery pack” on page 52
- “1020 Keyboard” on page 52
- “1030 Optical disk drive” on page 54
- “1040 Base cover assembly” on page 56
- “1050 Hard disk drive or solid-state hybrid drive” on page 58
- “1060 Wireless-LAN /Bluetooth card” on page 59
- “1080 Upper case” on page 61
- “1090 Audio board, audio board cable, power board, touch pad board cable, finger printer board, LED board and ODD switch board” on page 63
- “1100 System board” on page 66
- “1120 Speaker assembly, docking LED lens and docking bracket” on page 72
- “1130 LCD unit, docking board, docking cable and DC-in cable” on page 73

### Removal steps of the LCD front bezel

Remove the covers **1**, and then remove two screws **2**.

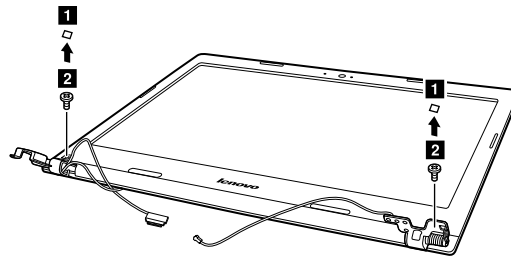

Step	Screw (quantity)	Color	Torque
<b>2</b>	M2.5 × 4mm, flat-headed, nylon-coated (2)	Silver	3.0 +/- 0.3kgf-cm

Remove the LCD front bezel in the direction shown by arrow **3**.

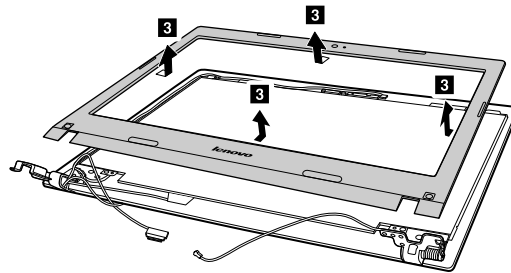

---

## 1150 LCD panel, EDP cable and hinges

For access, remove these FRUs in order:

- “1010 External battery pack” on page 52
- “1020 Keyboard” on page 52
- “1030 Optical disk drive” on page 54
- “1040 Base cover assembly” on page 56
- “1050 Hard disk drive or solid-state hybrid drive” on page 58
- “1060 Wireless-LAN /Bluetooth card” on page 59

- “1080 Upper case” on page 61
- “1090 Audio board, audio board cable, power board, touch pad board cable, finger printer board, LED board and ODD switch board” on page 63
- “1100 System board” on page 66
- “1120 Speaker assembly, docking LED lens and docking bracket” on page 72
- “1130 LCD unit, docking board, docking cable and DC-in cable” on page 73
- “1140 LCD front bezel” on page 76

### Removal steps of the LCD panel, EDP cable and hinges

Remove four screws **1** and then remove the LCD panel **2**.

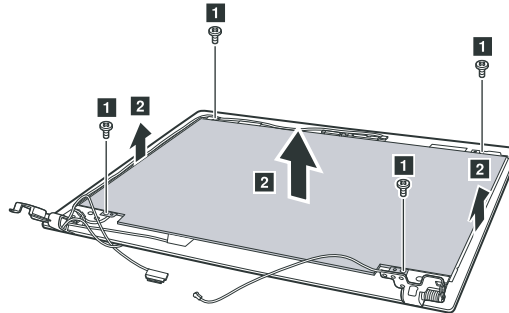

Step	Screw (quantity)	Color	Torque
<b>1</b>	M2.5 × 4mm, flat-headed, nylon-coated (4) (E40)	Black	3.0 +/- 0.3kgf-cm
	M2 × 3mm, flat-headed, nylon-coated (4) (E50)	Black	1.85 +/- 0.15kgf-cm

Disconnect the EDP cable connector **3**.

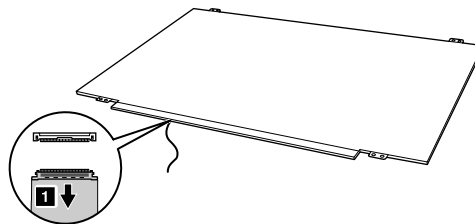

**When installing:** Ensure that the connector is attached firmly.

Remove two screws **4** and then remove the hinges in the direction shown by arrow **5**.

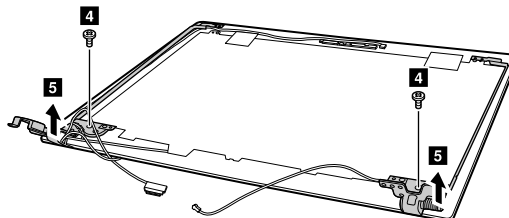

Step	Screw (quantity)	Color	Torque
<b>4</b>	M2.5 × 4mm, flat-headed, nylon-coated (2)	Black	3.0 +/- 0.3kgf-cm

Remove four screws **4** and the remove the hinges in the direction shown by arrow **5** (E50).

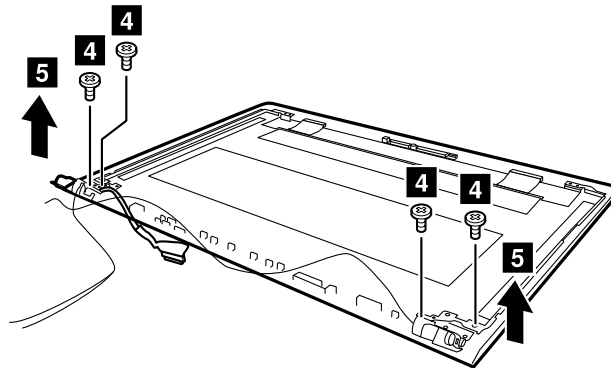

Step	Screw (quantity)	Color	Torque
<b>4</b>	M2.5 × 4mm, flat-headed, nylon-coated (4)	Silver	3.0 +/- 0.3kgf-cm

## 1160 Integrated camera and LCD cable

For access, remove these FRUs in order:

- “1010 External battery pack” on page 52
- “1020 Keyboard” on page 52
- “1030 Optical disk drive” on page 54
- “1040 Base cover assembly” on page 56
- “1050 Hard disk drive or solid-state hybrid drive” on page 58
- “1060 Wireless-LAN /Bluetooth card” on page 59
- “1080 Upper case” on page 61
- “1090 Audio board, audio board cable, power board, touch pad board cable, finger printer board, LED board and ODD switch board” on page 63
- “1100 System board” on page 66
- “1120 Speaker assembly, docking LED lens and docking bracket” on page 72
- “1130 LCD unit, docking board, docking cable and DC-in cable” on page 73
- “1140 LCD front bezel” on page 76
- “1150 LCD panel, EDP cable and hinges” on page 76



## Removal steps of the camera and LCD cable

Disconnect the connector **1**, remove the integrated camera from the LCD cover in the direction shown by arrow **2**, and then release the LCD cable from the cable guide **3**.

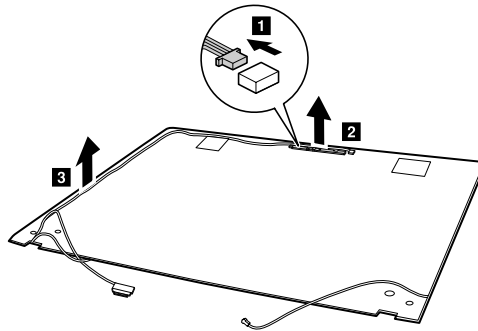

**When installing:** Stick the integrated camera to the top center of the LCD cover and adjust the placement of it to make sure the connector is attached firmly.

**Attention:** As you route the cables, ensure that they are not subject to any tension. Tension could cause the cables to be damaged by the cable guides, or a wire to be broken.

---

## 1170 Antenna assembly and LCD cover

For access, remove these FRUs in order:

- “1010 External battery pack” on page 52
- “1020 Keyboard” on page 52
- “1030 Optical disk drive” on page 54
- “1040 Base cover assembly” on page 56
- “1050 Hard disk drive or solid-state hybrid drive” on page 58
- “1060 Wireless-LAN /Bluetooth card” on page 59
- “1080 Upper case” on page 61
- “1090 Audio board, audio board cable, power board, touch pad board cable, finger printer board, LED board and ODD switch board” on page 63
- “1100 System board” on page 66
- “1120 Speaker assembly, docking LED lens and docking bracket” on page 72
- “1130 LCD unit, docking board, docking cable and DC-in cable” on page 73
- “1140 LCD front bezel” on page 76
- “1150 LCD panel, EDP cable and hinges” on page 76
- “1160 Integrated camera and LCD cable” on page 78

## Removal steps of the antenna assembly and LCD cover

Peel off the adhesive tapes securing the antenna boards, release the cables from the cable guide, and then remove the antenna assembly in the direction shown by arrow **1**.

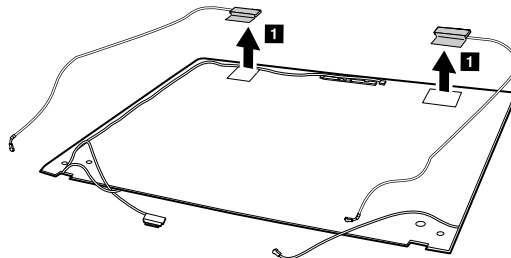

**When installing:** Route the antenna cables along the cable guides and secure the antenna boards with adhesive tapes. As you route the cables, make sure that they are not subjected to any tension. Tension could cause the cables to be damaged by the cable guides, or a wire to be broken.

---

## Appendix A. Notices

Lenovo may not offer the products, services, or features discussed in this document in all countries. Consult your local Lenovo representative for information on the products and services currently available in your area. Any reference to a Lenovo product, program, or service is not intended to state or imply that only that Lenovo product, program, or service may be used. Any functionally equivalent product, program, or service that does not infringe any Lenovo intellectual property right may be used instead. However, it is the user's responsibility to evaluate and verify the operation of any other product, program, or service.

Lenovo may have patents or pending patent applications covering subject matter described in this document. The furnishing of this document does not give you any license to these patents. You can send license inquiries, in writing, to:

*Lenovo (United States), Inc.  
1009 Think Place - Building One  
Morrisville, NC 27560  
U.S.A.  
Attention: Lenovo Director of Licensing*

LENOVO PROVIDES THIS PUBLICATION "AS IS" WITHOUT WARRANTY OF ANY KIND, EITHER EXPRESS OR IMPLIED, INCLUDING, BUT NOT LIMITED TO, THE IMPLIED WARRANTIES OF NON-INFRINGEMENT, MERCHANTABILITY OR FITNESS FOR A PARTICULAR PURPOSE. Some jurisdictions do not allow disclaimer of express or implied warranties in certain transactions, therefore, this statement may not apply to you.

This information could include technical inaccuracies or typographical errors. Changes are periodically made to the information herein; these changes will be incorporated in new editions of the publication. Lenovo may make improvements and/or changes in the product(s) and/or the program(s) described in this publication at any time without notice.

The products described in this document are not intended for use in implantation or other life support applications where malfunction may result in injury or death to persons. The information contained in this document does not affect or change Lenovo product specifications or warranties. Nothing in this document shall operate as an express or implied license or indemnity under the intellectual property rights of Lenovo or third parties. All information contained in this document was obtained in specific environments and is presented as an illustration. The result obtained in other operating environments may vary.

Lenovo may use or distribute any of the information you supply in any way it believes appropriate without incurring any obligation to you.

Any references in this publication to non-Lenovo Web sites are provided for convenience only and do not in any manner serve as an endorsement of those Web sites. The materials at those Web sites are not part of the materials for this Lenovo product, and use of those Web sites is at your own risk.

Any performance data contained herein was determined in a controlled environment. Therefore, the result obtained in other operating environments may vary significantly. Some measurements may have been made on development-level systems and there is no guarantee that these measurements will be the same on generally available systems. Furthermore, some measurements may have been estimated through extrapolation. Actual results may vary. Users of this document should verify the applicable data for their specific environment.

---

## Electronic emissions notices

For electronic emission information on Class B digital devices, refer to the corresponding information in the *User Guide*.



EU contact: Lenovo, Einsteinova 21, 851 01 Bratislava, Slovakia

---

## Trademarks

The following terms are trademarks of Lenovo in the United States, other countries or both:

Lenovo  
OneKey

Microsoft, Windows, and Windows Server are trademarks of the Microsoft group of companies.

DisplayPort, Mini DisplayPort (mDP), and VESA are trademarks of the Video Electronics Standards Association.

Other company, product, or service names may be the trademarks or service marks of others.

---

## Appendix B. Abbreviation table

The following table lists all abbreviations and acronyms used in this manual.

Abbreviation	Term
3G	third generation of mobile telecommunications technology
BGA	Ball Grid Array
BIOS	basic input/output system
CMOS	complementary metal-oxide semiconductor
COA	Certificate of Authentication
CRC	cyclic redundancy check
CRT	cathode ray tube
CRU	customer-replaceable unit
CTO	configure to order
EAIA	Enhanced Asset Information Area
ECA	Engineering Change Announcements
EEPROM	Electrically Erasable Programmable Read-Only Memory
EFI	Extensible Firmware Interface
EPO	emergency power-off
ESD	electrostatic discharge
EU	European Union
FCC	Federal Communications Commission
FRU	Field Replaceable Unit
GAV	General Announce Variant
GPU	graphics processing unit
HDD	hard disk drive
HDMI	high-definition multimedia interface
ICs	integrated circuits
ICCID	integrate circuit card identity
ISO	International Standardization Organization
LAN	local area network
LCD	liquid crystal display
MAC	media access control
MT	machine type
MTM	machine type and model
PC	personal computer
PCH	Platform Controller Hub
POST	power-on self-test
RAM	random-access memory

<b>Abbreviation</b>	<b>Term</b>
RF	radio frequency
RFID	radio-frequency identification
RI	ring indicator
RJ	registered jack
SATA	Serial Advanced Technology Attachment
SIM	subscriber identity module
SVP	supervisor password
TFTs	thin-film transistors
UEFI	Unified Extensible Firmware Interface
USB	Universal Serial Bus
UUID	universally unique identifier
VGA	video graphics array
VRAM	video random-access memory
WAN	wide area network



***lenovo***<sup>®</sup>